

INCH-POUND
------------

MIL-S-901D (NAVY)

17 March 1989

SUPERSEDING

MIL-S-901C (NAVY)

15 January 1963

(See 6.8)

## MILITARY SPECIFICATION

SHOCK TESTS, H.I. (HIGH-IMPACT) SHIPBOARD MACHINERY,  
EQUIPMENT, AND SYSTEMS, REQUIREMENTS FOR

This specification is approved for use by the Department of the Navy, and is available for use by all Departments and Agencies of the Department of Defense.

## 1. SCOPE

1.1 Scope. This specification covers shock testing requirements for ship board machinery, equipment, systems, and structures, excluding submarine pressure hull penetrations, (see 1.2.5). The purpose of these requirements is to verify the ability of shipboard installations to withstand shock loadings which may be incurred during wartime service due to the effects of nuclear or conventional weapons.

1.2 Classification.

1.2.1 Test categories. Tests shall be classified in accordance with one of the following test categories, as specified (see 3.1.2 and 6.2.1):

Beneficial comments (recommendations, additions, deletions) and any pertinent data which may be of use in improving this document should be addressed to: Commander, Naval Sea Systems Command, SEA 55Z3, Department of the Navy, Washington, DC 20362-5101 by using the self-addressed Standardization Document Improvement Proposal (DD Form 1426) appearing at the end of this document or by letter.
----------------------------------------------------------------------------------------------------------------------------------------------------------------------------------------------------------------------------------------------------------------------------------------------------------------------------------------------------------------------------------------------------------

AMSC N4571

AREA ENVR

DISTRIBUTION STATEMENT A. Approved for public release;  
distribution is unlimited.

## MIL-S-901D (NAVY)

Lightweight. The lightweight test is a test performed on the lightweight shock machine (see figure 1).

Medium weight. The medium weight test is a test performed on the medium weight shock machine (see figure 2).

Heavyweight. The heavyweight test is a test performed on a standard or large floating shock platform (see figures 3 and 4).

1.2.2 Shock grades. Items to be tested shall be classified in accordance with one of the following grades, as specified (see 3.1.3 and 6.2):

Grade A. Grade A items are items which are essential to the safety and continued combat capability of the ship.

Grade B. Grade B items are items whose operation is not essential to the safety and combat capability of the ship but which could become a hazard to personnel, to grade A items, or to the ship as a whole as a result of exposure to shock.

1.2.3 Equipment classes. Items to be tested shall be classified in accordance with one of the following classes, as specified (see 3.1.4 and 6.2):

Class I. Class I equipment is defined as that which is required to meet these shock requirements without the use of resilient mountings installed between the equipment and the ship structure or foundation.

Class II. Class II equipment is defined as that which is required to meet these shock requirements with the use of resilient mountings installed between the equipment and the ship structure or shipboard foundation.

Class III. Unless otherwise specified (see 3.1.6.3(e)), class III equipment is defined as that which has shipboard application both with and without the use of resilient mountings and is therefore required to meet both class I and class II requirements.

1.2.4 Shock test types. Tests shall be classified in accordance with one of the following types, as specified (see 3.1.5 and 6.2):

Type A. A type A test is a test of a principal unit. This is the preferred test. Principal units are items which are directly supported by the ship structure or by a foundation which is directly attached to the ship structure, and items

## MIL-S-901D(NAVY)

mounted in piping systems, ducting systems, and similar systems which are supported by ship structure. The shock response of a principal unit is primarily a function of the rigidity and mass of the item and the shipboard mounting structure, the shipboard mounting location, and the configuration of the item. Such items typically include diesel-generator sets, air conditioning plants, switchboards, radio transmitters, steam generators, missile launchers, and valves (if installed in piping which is supported by ship structure).

Type B. A type B test is a test of a subsidiary component. Subsidiary components are items which are the major parts of a principal unit. The shock response of the subsidiary component is significantly affected by that of the associated principal unit and all associated subsidiary components. The shock responses of the associated principal unit and all associated subsidiary components are significantly affected by that of the subsidiary component. Examples are the diesel engine of a diesel-generator set, the electric motor of an air conditioning unit, or the power supply section of a radio transmitter.

Type C. A type C test is a test of a subassembly. Subassemblies are items which are a part of a principal unit or a subsidiary component. The shock response of the subassembly is significantly affected by that of the associated principal unit or subsidiary component, but the shock response of the principal unit or subsidiary component is not significantly affected by the subassembly. Examples are thermometers, gauges, meters, relays, and resistors. The distinction between subassembly and assembly or part as used herein may be different than that used in various equipment specifications or other acquisition documents.

1.2.5 Mounting locations. Items shall be classified in accordance with one of the following mounting locations aboard ship, as specified (see 6.2):

Hull mounted. Hull mounted items are those mounted on:  
For surface ships. The main structural members of the ship including structural bulkheads and structural bulkhead stiffeners below the main deck, and shell plating above the waterline.

For submarines. The main structural members of the ship including, hull frames, structural bulkheads, and structural bulkhead stiffeners.

## MIL-S-901D(NAVY)

Deck mounted. Deck mounted items are those mounted on:  
For surface ships. Main deck and above, and decks, platforms, and non-structural bulkheads below the main deck.

For submarines. Decks, platforms, and non-structural bulkheads.

Shell mounted. Shell mounted items are those mounted on:

For surface ships. The shell plating below the waterline.

For submarines. The shell plating. (This specification does not cover underwater explosion testing of items which penetrate the submarine pressure hull (see 1.1).)

Wetted-surface mounted. Wetted-surface mounted items are those mounted:

For surface ships. External to the hull and below the waterline.

For submarines. External to the pressure hull.

1.2.6 Mounting plane aboard ship. Items shall be classified in accordance with one of the following planes of mounting aboard ship, as specified (see 6.2):

- Base
- Front or face
- Back
- Top
- Combination. (such as base and back)
- Other

1.2.7 Mounting orientation aboard ship. Items shall be classified in accordance with one of the following intended orientations aboard ship, as specified (see 6.2):

Unrestricted as to orientation aboard ship  
 Restricted

- Shaft, front, face, principal axis, and so forth, parallel to fore-and-aft axis of ship
- Shaft, front, face, principal axis, and so forth, perpendicular to fore-and-aft axis of ship
- Other

## 2. APPLICABLE DOCUMENTS

### 2.1 Government documents.

## MIL-S-901D (NAVY)

2.1.1 Specifications and standards. The following specifications and standards form a part of this document to the extent specified herein. Unless otherwise specified, the issues of these documents are those listed in the issue of the Department of Defense Index of Specifications and Standards (DoDISS) and supplement thereto, cited in the solicitation (see 6.2).

## SPECIFICATIONS

## MILITARY

- MIL-S-1222 - Studs, Bolts, Hex Cap Screws, and Nuts.
- MIL-P-15024 - Plates, Tags and Bands for Identification of Equipment.
- MIL-P-15024/5 - Plate, Identification.
- MIL-M-17185A - Mounts, Resilient; General Specifications and Tests for (Shipboard Application)
- MIL-W-21157 - Weldment, Steel, Carbon and Low Alloy (Yield Strength 30,000 - 60,000 PSI).
- MIL-E-22200/1 - Electrodes, Welding, Mineral Covered, Iron- Powder, Low-Hydrogen, Medium and High Tensile Steel, As Welded or Stress-Relieved Weld Application.

## STANDARDS

## FEDERAL

- FED-STD-H28 - Screw-Thread Standards for Federal Services.

## MILITARY

- MIL-STD-22 - Welded Joint Design.
- MIL-STD-298 - Nondestructive Testing, Welding, Quality Control, Material Control and Identification and Hi-Shock Test Requirements For Naval Shipboard Use.

(Unless otherwise indicated, copies of federal and military specifications, standards, and handbooks are available from the Naval Publications and Forms Center, (ATTN: NPODS), 5801 Tabor Avenue, Philadelphia, PA 19120-5099.)

## MIL-S-901D (NAVY)

2.1.2 Other Government drawings. The following other Government drawings form a part of this document to the extent specified herein. Unless otherwise specified, the issues are those cited in the solicitation.

## DRAWINGS

- BUSHIPS 10-T-2145-L - HI Shock Testing Machine, Lightweight.
- BUSHIPS N0807-655947 - HI Shock Testing Machine, Medium Weight.
- BUSHIPS 645-1973904 - Floating Shock Platform, General Arrangement and Details.

(Application for copies of NAVSEA drawings should be addressed to: Commanding Officer, Naval Ordnance Station, (Attn: Code 802), Louisville, KY 40214.)

2.2 Non-Government publications. The following documents form a part of this document to the extent specified herein. Unless otherwise specified, the issues of the documents which are DoD adopted shall be those listed in the issue of the DoDISS cited in the solicitation. Unless otherwise specified, the issues of documents not listed in the DoDISS are the issues of the documents cited in the solicitation (see 6.2).

## AMERICAN NATIONAL STANDARDS INSTITUTE (ANSI)

- B46.1 - Surface Texture (Surface Roughness, Waviness and Lay). (DoD adopted)
- Y14.5 - Dimensioning and Tolerancing. (DoD adopted)
- Y14.6 - Screw Thread Representation. (DoD adopted)

(Application for copies should be addressed to the American National Standards Institute, Inc., 1430 Broadway, New York, NY 10018.)

## AMERICAN WELDING SOCIETY (AWS)

- A2.4 - Symbols for Welding and Nondestructive Testing, Including Brazing. (DoD adopted)
- A3.0 - Standard Welding Terms and Definitions, Including Terms for Brazing, Soldering, Thermal Spraying, and Thermal Cutting. (DoD adopted)

## MIL-S-901D(NAVY)

(Application for copies should be addressed to the American Welding Society, Inc., 550 N.W. LeJeune Road, P.O. Box 351040, Miami, FL 33135.)

(Non-Government standards and other publications are normally available from the organizations that prepare or distribute the documents. These documents also may be available in or through libraries or other informational services.)

2.3 Order of precedence. In the event of a conflict between the text of this document and the references cited herein (except for related associated detail specifications, specification sheets or MS standards), the text of this document takes precedence. Nothing in this document, however, supersedes applicable laws and regulations unless a specific exemption has been obtained.

### 3. REQUIREMENTS

3.1 Shock testing requirements. Shock testing requirements shall be met either by shock testing of the item in accordance with 3.1.1 through 3.1.15, or by extension of previously approved shock tests in accordance with 3.2.

3.1.1 Establishment of requirements. Requirements contained herein are intended to establish general shock test criteria, and to provide a basis for selection by the contracting activity or contractor of detailed shock test requirements (see 6.2) which must be tailored to suit the design, function, and application of the specific item to be tested.

3.1.1.1 Contractor development of requirements. Where acquisition requirements are not specified in the contract (see 6.2), the contractor shall develop the required information on the basis of this specification and on the basis of the contractor's knowledge of the design, function, and intended application of the item requiring tests. In cases where information required by the contractor to permit development of detailed testing requirements is not available to the contractor, such information shall be requested from the contracting activity or acceptance authority.

3.1.1.2 Approval of detailed requirements. When specified in the contract or order, detailed test procedures for heavyweight shock tests and other acquisition requirements listed in 6.2 which are independently developed by the contractor shall be prepared (see 6.2.2). When required by the contract or order, fixture drawings shall be prepared (see 6.2.2) and justification shall be prepared as to why the test fixture satisfactorily meets the requirements of this specification (see 6.2.2). Acquisition

## MIL-S-901D(NAVY)

documents may require that detailed test procedures and other information required by 6.2 which are independently developed by the contractor for lightweight and medium weight shock tests also be approved by the acceptance authority prior to installing the item for shock tests (see 6.2.1). Absence of specified requirements for prior approval of such information does not prohibit the contractor from submitting such information for approval prior to testing.

3.1.2 Selection of test category (see 1.2.1). Shell mounted and wetted surface mounted items shall be subject to heavyweight shock testing. Other items shall be proven acceptable by either lightweight, medium weight, or heavyweight shock testing, provided that the following limitations are complied with:

(a) Lightweight shock test. The total weight supported by the lightweight shock machine anvil plate (excluding weight of anvil plate itself but including all structure and equipment added to the anvil plate) shall not exceed 550 pounds. Practical size limitations shall not be exceeded. Equipment which would normally be tested on the lightweight shock machine but which is mounted on or incorporates resilient mounts or flexible mounting elements which have a deflection capability under shock loading of 1-1/2 inches or more in any direction shall instead be subject to medium weight or heavyweight shock testing.

(b) Medium weight shock test. The total weight supported by the medium weight shock machine anvil table shall not exceed 7,400 pounds. Practical size limitations shall not be exceeded. Equipment which would normally be tested on the medium weight shock machine, but which is mounted on or incorporates resilient mounts or flexible mounting elements which have a deflection capability under shock loading in excess of 3 inches in any direction, shall instead be subject to heavyweight shock testing.

(c) Heavyweight shock test. Weight and center of gravity limitations applicable to heavyweight shock testing are shown on figures 5 and 6. Weight, size, and center of gravity limitations applicable to the standard floating shock platform (see figure 5) shall be assumed to apply, unless acquisition documents specifically state the utilization of the large floating shock platform (see figure 6) is permitted (see 6.2.1). The acceptance authority will consider contractor requests to utilize the large floating shock platform in cases where acquisition documents do not specifically prohibit use of this test platform. Contracting activities or the acceptance authority shall obtain approval from the Naval Sea Systems Command (Ship Protection Division) prior to specifying or permitting shock tests requiring utilization of the

## MIL-S-901D(NAVY)

large shock platform.

(d) Separately specified limitations. Acquisition documents may require use of alternate Government-owned shock test vehicles, may specify the shock test category, or may impose additional limitations upon selection of the shock test category (see 6.2.1).

3.1.3 Selection of shock grade (see 1.2.2). Shock grade shall be as specified (see 6.2). If shock grade is not specified, acceptance of tested items shall be based upon grade A requirements (see 3.1.10.1), unless otherwise approved by the acceptance authority.

3.1.4 Selection of equipment class (see 1.2.3). Equipment class shall be as specified (see 6.2) or, if no class is specified, shall be selected to suit the classes described in 1.2.3.

3.1.5 Selection of shock test type (see 1.2.4). Shock test type shall be as specified (see 6.2).

3.1.5.1 Type A. The type A test (principal unit test) shall be required in all cases, except as indicated in 3.1.5.2 and 3.1.5.3. The fact that subsidiary components and subassemblies of a principal unit have passed type B or C shock test does not affect requirements for type A testing.

3.1.5.2 Type B. The type B test (subsidiary component test) shall be required in cases where type A testing is not possible due to heavyweight shock test size or weight limitations (see 3.1.2(c) and 6.2). The fact that subassemblies or a subsidiary component have passed type C tests does not affect requirements for type B testing. Type B testing may also be required by specifications (or may be recommended by the contractor for approval by the acceptance authority) to suit any of the following situations:

(a) In cases where a subsidiary component (such as a electric motor) is associated with a wide variety of principal units, type B testing of the item may be required by the acquisition documents for the purpose of providing reasonable assurance that the item will also pass subsequent type A tests (when tested as a part of one or more principal units), and to improve opportunities for shock test extension.

(b) In cases where a subsidiary component has failed during shock testing of a principal unit, repeat shock testing of the subsidiary component only (by type B testing) may be permitted by the acceptance authority in lieu of repeat testing of the entire

## MIL-S-901D (NAVY)

principal unit (see 3.1.11(a)).

**3.1.5.3 Type C.** The type C test (subassembly test) shall be performed only when specified (see 6.2) or as approved by the acceptance authority. The type C test may be required by specifications (or recommended by the contractor for consideration by the acceptance authority) for the same reasons as indicated in 3.1.5.2. The contractor may also recommend performance of type C tests in cases where subassemblies associated with a principal unit or subsidiary component are not available at the time the principal unit or subsidiary component is scheduled for shock testing (see 3.1.7.3).

**3.1.6 Mounting requirements.** Items shall be mounted upon shock machines (see figures 1 and 2) or upon floating shock platforms (see figures 3 and 4) for shock testing in the manner specified (see 6.2). Shock machines or floating shock platforms shall comply with the appropriate Government drawing specified in 2.1.2. Paragraphs 3.1.6.1 through 3.1.6.3 provide requirements applicable to selection or design of shock test mounting fixtures by the contracting activity, and provide requirements which shall be observed by the contractor in the event that the required mounting fixture design is not specified by the acquisition documents. Development of shock test mounting requirements by the contractor will often be necessary, since these requirements are often contingent upon characteristics of the tested item (such as size, weight, and means of attachment) which are not known to the contracting activity at the time of specification preparation.

**3.1.6.1 Lightweight test fixtures.** For lightweight shock tests, items to be tested shall normally be attached to the anvil plate of the lightweight shock machine by means of standard mounting fixtures 4A, 4C, 6D-1, 6D-2, 6E, or 11-C as shown on figures 7 through 12. If the required mounting fixture is not specified, an appropriate standard fixture shall be selected by the contractor (see 3.1.6.3), or the contractor may recommend the use of a nonstandard fixture which complies with 3.1.6.3 for approval by the acceptance authority. When the equipment has been mounted for test upon a standard fixture, its position upon the fixture shall not be changed during the course of the test.

**3.1.6.2 Medium weight test fixtures.** For medium weight shock tests, items to be tested shall normally be attached to the medium weight shock machine anvil table by means of the standard mounting fixtures referred to in 3.1.6.2.1 and 3.1.6.2.2. If the required mounting fixtures are not specified, appropriate standard fixtures shall be selected by the contractor (see 3.1.6.3), unless use of one or more nonstandard fixtures which comply with 3.1.6.3 is

## MIL-S-901D(NAVY)

recommended by the contractor and approved by the acceptance authority. Note that two different test fixtures shall be selected for testing of a given item; one fixture is used to support the tested item on the shock machine in its normal shipboard mounting attitude (to produce shock loadings in the vertical direction), and a second fixture is used to support the tested item in an inclined position (to produce shock loadings in the athwartship direction). Additional criteria for selection and use of medium weight test fixtures are contained in 3.1.6.2.1 through 3.1.6.2.3 and in 3.1.8.2.

3.1.6.2.1 Mounting Fixtures for base-mounted items (medium weight test). For the portion of the shock test series which is intended to produce shock loadings in the vertical direction (see 3.1.8.2), base-mounted items (items mounted to horizontal surfaces aboard ship) shall be attached to the anvil table by means of the standard mounting platform shown on figures 13 and 14. For the portion of the test series which is intended to produce shock loadings in the athwartship direction (see 3.1.6.2.3), base-mounted items shall be mounted for tests on a standard inclined fixture (see figures 16 and 17) or on a similarly designed nonstandard fixture. To facilitate installation of some items on the medium weight shock machine, items may be inclined 90 degrees (using a mounting fixture such as shown on figure 15).

3.1.6.2.2 Mounting fixtures for bulkhead mounted items (medium weight test). For the portion of the shock test series which is intended to produce shock loadings in the vertical direction (see 3.1.8.2), bulkhead-mounted items (items mounted to vertical surfaces aboard ship) shall be attached to the anvil table by means of the standard bulkhead fixture shown on figure 15 or by a similarly designed nonstandard fixture. For the portion of the test series which is intended to simulate shock loadings in the athwartship direction (see 3.1.6.2.3), bulkhead mounted items shall be mounted for shock tests in any of the following configurations:

- (a) Mount the item in an inclined position upon a standard inclined fixture (figures 16, 17, and 18 show applicable fixtures) or upon a similar nonstandard fixture.
- (b) If considered practical by the shock test facility (and if within the limitations of 3.1.2(b)), mount the item upon a vertical test fixture (such as shown on figure 15) and then mount this assembly upon an inclined test fixture of the type shown on figures 16 or 17.
- (c) Mount the item horizontally (inclined 90 degrees

## MIL-S-901D(NAVY)

relative to its shipboard mounting position) upon the standard mounting platform shown on figures 13 and 14. Mounting of bulkhead mounted items in this fashion for shock tests is subject to prior approval by the acceptance authority.

3.1.6.2.3 Special requirements for inclined mounting. When inclined fixtures are used, the item to be tested shall be mounted on the fixture such that the item is inclined in the same direction as the item would incline aboard ship if the ship were to roll about its fore-and-aft axis (see 6.2). If the item is to be oriented in different directions aboard ship, the item shall be mounted and tested in two different inclined orientations to simulate shock loadings in both principal horizontal directions. (If the inclined fixture shown on figure 18 is used, it is not necessary to test the item in two different inclined orientations.) Inclined fixtures shall incline the tested item at least 30 degrees relative to the normal (shipboard) mounting position.

3.1.6.3 Design and selection of test fixtures. The following requirements apply to selection of standard test fixtures in cases where none is specified, to design of nonstandard fixtures for lightweight and medium weight tests, and to design of heavyweight test fixtures:

- (a) Except as indicated by 3.1.6.3(c), principal units shall be mounted for testing in a manner which dynamically simulates the most severe (normally, the stiffest) mounting condition likely to be encountered in the actual shipboard installation.
- (b) Subsidiary components and subassemblies shall be mounted in a manner which simulates the dynamic characteristics of the associated principal unit. If more than one installation is possible, the most severe installation shall be implemented.
- (c) Standard shock machine mounting fixtures are intended to represent hull mounted conditions, and are typically stiffer than would be required to simulate deck mounted conditions. Use of standard mounting fixtures for tests of deck-mounted items is acceptable for class I tests only. Heavyweight testing is recommended in cases where simulation of deck-mounted conditions is desired; such conditions are difficult to simulate on shock machines. Fixtures intended to simulate deck-mounted conditions shall possess fundamental response frequencies (with the equipment installed on the

## MIL-S-901D(NAVY)

fixture) not lower than 25 Hertz (Hz) in each principal shock direction, for class I tests, unless otherwise specified (see 6.2.1). For class II tests, fixtures intended to simulate deck-mounted conditions shall possess a fundamental frequency (with the equipment installed on the fixture) of 12 to 16 Hz in the vertical direction unless otherwise specified (see 6.2.1).

- (d) Plastic yielding or cracking of test fixtures during shock tests shall be considered unacceptable, unless otherwise specifically approved by the acceptance authority. (Acceptance of test fixture yielding or cracking by the acceptance authority shall be contingent upon demonstration by the contractor that such yielding or cracking did not reduce the validity of the test.)
- (e) Tested items shall be attached to their shock test fixtures in accordance with the manufacturer's installation drawings. This method of mounting shall reflect the intended shipboard installation. Class II and class III equipments shall be mounted for tests upon the same type and arrangement of resilient mountings (including snubbers) as will be used to support the equipment aboard ship. Note: Shock testing of class III items in the rigidly mounted configuration solely to qualify the items for mounting in both rigidly and resiliently mounted configurations may be permitted by applicable acquisition documents. Permission to do so is subject to the provision that the resilient mounts, subbase, hold-down means, and other components unique to the resiliently mounted installation are selected, designed, or shock tested to suit separately invoked shock requirements (see 1.2.3 and 6.2.1).
- (f) Test fixtures for hull-mounted heavyweight test items shall be attached directly to the standard floating shock platform inner bottom structure (see figure 3) or to transverse or longitudinal hull stiffeners of the large floating shock platform (see figure 4) and shall be designed in accordance with 3.1.6.3(a).
- (g) Mounting fixtures for wetted-surface mounted items shall be attached to the underside of a floating shock platform. The mounting fixture shall be arranged such that the tested item is exposed to the direct explosion

## MIL-S-901D(NAVY)

pressure wave during test. The test fixture shall be located so as to minimize (insofar as practical) the horizontal distance between the tested item and the side of the floating shock platform which faces the explosive charge during the most severe test shot.

- (h) Unless otherwise specified (see 6.2.1), the standard floating shock platform shall be utilized for shock testing of wetted-surface mounted transducers. Wetted portions of the transducer face shall be positioned at a horizontal standoff distance no greater than 21 feet from the explosive charge during the most severe test and no less than 3 feet below the underside of the floating shock platform.
- (i) Shell mounted items shall be attached directly to the standard floating shock platform inner bottom structure.
- (j) Acquisition documents may specify additional requirements pertaining to selection of standard test fixtures or to the required design of nonstandard fixtures (see 6.2.1).
- (k) Where hold-down bolts for test items are specified to be torqued to specific values in the ship installation, the hold-down bolts shall be torqued to these values in the shock test installation (see 3.1.8.6 and 6.2).
- (l) Bolting used to secure items to the shock test fixtures or foundations shall conform to MIL-S-1222.

### 3.1.7 Simulation of items during shock tests.

3.1.7.1 Simulation of shipboard connections. In cases where piping, sway braces, drive shafts, control linkages, or similar items or structures will be connected to the shock tested item in the shipboard installation, characteristics of the connection which could significantly influence shock damage potential shall be represented during the shock test. Specific requirements for simulation of shipboard connections during shock tests shall be as specified (see 6.2) or, if not specified, shall be developed by the contractor on the basis of the following and for acceptance authority approval.

- (a) Rigid dummy masses may be used to simulate inertial effects of the connected item. Dummy masses shall be attached to the tested item by the same means as will

## MIL-S-901D (NAVY)

be used aboard ship to attach the actual connected item. Dummy masses shall not be fabricated from brittle materials such as cast iron. The weight of dummy masses shall normally be equal to the static load exerted upon the tested item aboard ship due to the weight of the connected item. For simulation of extended and relatively flexible connected items such as piping, use of dummy masses equal in weight to the weight of the first 5 feet or first 10 diameters (whichever is of greater weight) of the connected item will be considered acceptable, unless otherwise specified (see 6.2.1). For purposes of simulating piping loads, the weight of contained fluid shall be represented in addition to piping weight. Acquisition documents may invoke specific requirements for the weight or design of dummy masses to be used during tests (see 6.2.1).

- (b) In cases where tested items will derive a substantial degree of support from relatively rigid shipboard connections (such that the connections effectively serve as secondary foundations), the restraining effects of these connections shall be simulated during the shock test.
- (c) For shock tests of resiliently mounted items, connections between the resiliently mounted item and other (separately mounted) items shall be represented during the shock test if shock-induced relative motion between the resiliently mounted item and the connected item could result in damage to the tested item or to the connection.

3.1.7.2 Simulation of subsidiary components. All subsidiary components which comprise a principal unit shall be shock tested with the principal unit unless the acceptance authority specifically permits simulation of one or more (but not all) of a group of identical subsidiary components which are installed on a common subbase (see 6.2.1). Dummy masses used for simulating subsidiary components shall possess the same weight, center-of-gravity, and means of attachment as the actual subsidiary component.

3.1.7.3 Simulation of subassemblies. The requirements of 3.1.7.2 also apply to simulation of subassemblies during type A or type B tests. Requests for permission to simulate subassemblies during type A or type B tests will be considered by the acceptance authority in cases where subassemblies associated with a principal

## MIL-S-901D(NAVY)

unit or subsidiary component are not available at the time the principal unit or subsidiary unit is scheduled to be tested. Subassemblies which are not tested with their associated principal unit or subsidiary component shall be subject to type C testing (see 3.1.5.3).

**3.1.8 Conduct of shock tests.** Shock tests shall be conducted in accordance with 3.1.8.1 through 3.1.8.6 and with the accepted shock test procedures required by the data ordering document (see 6.2.2). In order to assure consistent shock hardening, contracting activities or acceptance authorities shall not specify or permit variation from the basic shock test parameters of 3.1.8.1 through 3.1.8.3 which define the severity of the shock test. In the event that modification of these basic shock test parameters is required, approval of the modification shall be obtained from the Naval Sea Systems Command.

**3.1.8.1 Lightweight shock test.** For all items subject to lightweight shock testing, three blows at hammer heights of 1, 3, and 5 feet shall be applied parallel to each of three mutually perpendicular axes of the item being tested. This is accomplished by attaching the test item by fixtures to an anvil plate and striking the anvil plate by top, back, and side blows. The sequence of the testing may be varied at the discretion of the contracting activity and the contractor. In some cases, it may be more beneficial to conduct a 1-foot test in each of the three mutually perpendicular axes, followed by the 3-foot tests and then the 5-foot tests. The above series of nine blows shall be conducted for each operating condition to be represented during shock test. Operating conditions to be represented during lightweight shock tests shall be as specified (see 6.2). If this information is not specified, the contractor shall select operating conditions to be represented during tests in accordance with 3.1.8.4. Separate items may be substituted for each additional set of nine blows, if desired by the contractor.

**3.1.8.2 Medium weight shock test.** For all items subject to medium weight shock testing, a minimum of six blows (of three groups of two blows each) shall be applied. For each group, the height of the hammer, number of blows, and anvil table travel shall be as shown in table I. One blow of each group shall be conducted with the tested item mounted in its normal attitude (to simulate shipboard shock loadings in the vertical direction). The other blow of each group shall be conducted with the tested item mounted in the inclined position (to simulate shipboard shock loadings in the athwartship direction). In cases where the tested item is required to be mounted in two different inclined orientations to suit 3.1.6.2.3, three blows per group (nine blows total) shall

## MIL-S-901D (NAVY)

be required to test the item in all of its mounting orientations. Additional groups of blows may be required to permit testing of the item in all of its normal operating modes (see 3.1.8.4). Operating conditions to be represented during any particular group or groups of blows shall be as specified (see 6.2). If this information is not specified, the contractor shall select operating conditions to be represented during tests in accordance with 3.1.8.4. Separate items may be substituted for items which have been exposed to six (or more) medium weight shock test blows subject to approval of the acceptance authority.

TABLE I. Test schedule for medium weight shock machine.

Group number _____	I	II	III
Number of blows _____	2	2	2
Anvil table travel, inches _____	3	3	1.5
Total weight on anvil table (pounds) <sup>1</sup>	Height of hammer drop <sup>2</sup> (feet)		
Under 1,000	0.75	1.75	1.75
1,000 - 2,000	1.0	2.0	2.0
2,000 - 3,000	1.25	2.25	2.25
3,000 - 3,500	1.5	2.5	2.5
3,500 - 4,000	1.75	2.75	2.75
4,000 - 4,200	2.0	3.0	3.0
4,200 - 4,400	2.0	3.25	3.25
4,400 - 4,600	2.0	3.5	3.5
4,600 - 4,800	2.25	3.75	3.75
4,800 - 5,000	2.25	4.0	4.0
5,000 - 5,200	2.5	4.5	4.5
5,200 - 5,400	2.5	5.0	5.0
5,400 - 5,600	2.5	5.5	5.5
5,600 - 6,200	2.75	5.5	5.5
6,200 - 6,800	3.0	5.5	5.5
6,800 - 7,400	3.25	5.5	5.5

<sup>1</sup> Total weight on anvil table is the sum of equipment weight plus weight of all mounting fixtures.

<sup>2</sup> The height of hammer drop shall be measured by means of the existing markings on the scale of the machine, no corrections being made for the added anvil table travel for the blows of groups I and II.

3.1.8.3 Heavyweight shock test. The heavyweight shock test series consists of four shots, with test conditions as indicated by table II. Additional test shots at standoff distances greater than

## MIL-S-901D (NAVY)

shot 1 standoff may be required by specifications (see 6.2.1), or may be conducted at the contractor's option in cases where it is desired to evaluate performance of the tested item at low shock levels before commencing the standard test series. Operating conditions to be represented during each shot shall be as specified (see 6.2). If this information is not specified, the contractor shall select operating conditions to be represented during tests in accordance with 3.1.8.4.

TABLE II. Test schedule for heavyweight shock testing.

Test conditions	Standard floating shock platform	Large floating shock platform
Depth of explosive charge below water surface (for all shots)	24 feet	20 feet
Explosive charge weight/composition	60 lbs/HBX-1	300 lbs/HBX-1
Shot direction <sup>1</sup> :		
Shot 1	Fore-and-aft	Fore-and-aft
Shots 2, 3, and 4	Athwartship	Athwartship
Standoff <sup>2</sup> :		
Shot 1	40 feet	110 feet
Shot 2	30 feet	80 feet
Shot 3	25 feet	65 feet
Shot 4	20 feet	50 feet

<sup>1</sup> For the fore-and-aft direction shot, the explosive charge shall be located relative to the floating shock platform so as to represent an underwater explosion occurring off the bow or stern of the ship in which the equipment is to be installed (see 6.2). Athwartship shots shall be oriented to represent explosions abeam of the ship.

<sup>2</sup> Refers to the horizontal distance between the explosive charge centerline and the near side of the floating shock platform.

## MIL-S-901D(NAVY)

**3.1.8.4 Operation of equipment during shock tests.** Items shall be shock tested in each of the operating conditions specified in (6.2). If operating conditions required for tests are not specified, the contractor shall select operating conditions to be represented during tests based upon the following requirements:

- (a) Grade A items shall be tested while operating in each of their normal operation modes, positions, or conditions. For example, motors shall be tested while running at rated speed and at standstill, contractors shall be tested in open and closed positions, and equipment shall be tested at rated pressure and, if applicable, energized at voltages, current, and load conditions which will aid in detecting intermittent equipment problems. Equipment shall be tested at the temperature indicated in 6.2. Unless otherwise specified (see 6.2), test may be conducted at the prevailing ambient temperature of the shock test facility. For emergency or standby equipment, the normal operating mode shall consider the equipment to be operating. Grade B items shall be operated during shock tests only if operation during exposure to shock significantly increases the potential for shock damage of a type which would violate acceptance criteria (see 3.1.10.2).
- (b) For items with many possible normal operating modes, positions, or conditions, representative operating conditions which are judged most critical from a shock standpoint shall be represented during shock tests. Unless otherwise specified (see 6.2), no more than the three most significant operating conditions need be represented during shock tests.
- (c) For medium weight tests, the normal operating mode shall be represented during group I and III blows, and other modes of operation shall be represented during group II blows. (If three group operating modes are to be represented, two series of group II blows shall be required.)
- (d) For heavyweight tests, the normal operating mode shall be represented during shots 1 and 4 (see 3.1.8.3). The next most likely operating mode shall be represented during shot 3, and the least likely operating mode during shot 2. The acceptance authority shall specify or approve selection of heavyweight test operating modes to be represented (see 3.1.1, 3.1.1.2, and 3.1.8.3).

## MIL-S-901D (NAVY)

- (e) Where operation of items during tests as required above is not practical due to test facility limitations, the required operating conditions shall be simulated to the maximum extent practical. Acquisition documents may indicate requirements for partial simulation of actual shipboard operating conditions in such cases (see 6.2.1). Simulation of operating conditions, if other than as specifically permitted in acquisition documents, shall be subject to acceptance authority approval.

3.1.8.5 Monitoring of items during tests. Performance of tested items shall be monitored during shock tests to the extent necessary to verify compliance with shock test acceptance criteria (see 3.1.10). Acquisition documents may indicate requirements for monitoring of items during shock tests (see 6.2). Instrumentation is not generally required, but in order to monitor performance, instrumentation may be required for any particular test as specified in the acquisition documents.

3.1.8.6 Correction of damage during shock tests. Exposed bolting, screws, and similar exposed fasteners associated with the tested item may be tightened before each test blow or shot only as necessary to compensate for loosening due to seating-in of mating surfaces, as demonstrated by suitable pre- and post- shock measurements. If it cannot be demonstrated (e.g., by bolt length measurements) that fasteners have not yielded, the fasteners shall not be retightened and subsequent shock blows and performance tests shall be conducted with the fasteners in the as-found condition. See 3.1.6.3(k) for torquing requirements for test item hold-down bolts. Torques for applicable bolting shall be measured and recorded following each shock test blow or shot. Excessive yielding or loosening of fasteners shall be considered as a violation of shock test acceptance criteria. Yielding or loosening of fasteners and yielding or cracking of structural members or component parts shall be reported in shock test reports when such reports are required by the contract or order (see 6.2.2).

3.1.9 Post-shock test functional testing and inspection. After completion of shock tests, grade A and B items shall be given tests and inspections in accordance with 3.1.9.1 and 3.1.9.2 to determine if specified shock test acceptance criteria (see 3.1.10) have been satisfied. Detailed requirements for functional testing and inspection of tested items shall be as specified for the particular item (see 6.2). If these requirements have not been specified, the contractor shall develop functional testing and inspection criteria based upon the requirements of 3.1.9.1 and 3.1.9.2 (see 6.2.2).

## MIL-S-901D (NAVY)

3.1.9.1 Functional testing. Post-shock test functional testing is required for grade A items only. When practicable, functional testing at the test site is desired to avoid disputes regarding possibility of additional damage during shipment. If functional testing at the test site is considered feasible and is desired, this shall be specified in the acquisition documents. Unless otherwise approved by the acceptance authority, functional performance testing shall be accomplished prior to disassembly or repair of the item, and shall be accomplished prior to installation of the item in the ship. In general, functional performance tests shall include, but not necessarily be limited to, checking the input-output of the component or equipment, its operating temperatures (bearing, coil windings), and cyclic tests, as appropriate to determine compliance with acceptance criteria (see 3.1.10). Hydraulic, pneumatic, and fluid systems equipment shall be hydrostatically tested to demonstrate strength and to test for leaks, if not previously checked during shock testing. Electrical equipment shall be tested for shorts to detect breakdown of insulation.

3.1.9.2 Inspection. All shock tested grade A items shall be disassembled and inspected for breakage, deformation, and misalignment. Where cracking would be a cause for rejection, areas highly stressed during shock tests shall be checked for cracks using dye penetrant, magnetic particle, or other tests. Dimensions of critical tolerance areas shall be checked. Inspection of grade B equipment for purposes of determining compliance with shock test acceptance criteria shall be limited to the extent required to reveal the existence of any condition that could create a hazard (see 3.1.10.2 and 6.6.6).

3.1.10 Shock test acceptance criteria.

3.1.10.1 Grade A items. Grade A items shall withstand shock tests conducted in accordance with this specification without unacceptable effect upon performance and without creating a hazard (see 6.6.6). If applicable specifications do not define shock test acceptance criteria (see 6.2), the contractor shall develop these criteria in accordance with the following:

- (a) For each performance criterion specified for the item by the applicable military specification or purchase order, a corresponding shock test acceptance criterion shall be developed which indicates the degree, if any, of degradation of performance allowable as a result of exposure to shock. Allowed degradation of performance shall be limited to that which will have no unacceptable effect upon performance of the item,

## MIL-S-901D (NAVY)

either by itself or in combination with other forms of allowed degradation.

- (b) Each shock test acceptance criterion shall be identified with requirements to monitor the item during shock tests and post test functional tests or inspections as required to verify compliance with the acceptance criterion (see 6.2). Monitoring requirements should distinguish between acceptance criteria which can be satisfied by inspection immediately following each blow (e.g., trip throttle valves and quick closing valves remain open, pressurized components remain leak tight) and criteria for which monitoring must be continuous throughout the shock motion (e.g., there shall be no intermittent short circuits and open circuits in electrical equipment, no abnormal output of control, governor regulating equipment).
- (c) Shock test acceptance criteria shall be expressed primarily in terms of performance parameters which can be readily evaluated during or after shock tests. Minor physical damage to the tested item, such as small cracks, minor yielding of structure, out-of-tolerance clearances, and similar damage shall not be cause for shock test disapproval unless such damage causes unacceptable impairment of equipment performance, results in a hazard, or results in substantially shortened equipment useful life.
- (d) Momentary malfunction of any grade A item shall be considered acceptable only if it is automatically self-correcting and only if no consequent derangement, maloperation, or compromise of the grade A capability is caused by the momentary malfunction. For momentary malfunctions to be considered acceptable, the intended use of the component must be known and the shock test report must include a description of any momentary malfunctions encountered during testing and the rationale demonstrating that these malfunctions are acceptable for the intended use. Acceptance criteria for likely momentary malfunctions, where known in advance of shock testing, shall be included in the shock test procedure. Acceptance criteria for momentary malfunctions shall be consistent both with the intended use of the component and with any information provided by acquisition documents regarding momentary malfunctions under shock.

## MIL-S-901D(NAVY)

(See 6.4(t) for examples of acceptable versus unacceptable momentary malfunctions.)

- (e) Shock test acceptance of grade A equipments shall not be contingent upon the ability of the item to satisfy noise and vibration standards after exposure to shock unless otherwise specified (see 6.2.1).
- (f) Shock test acceptance criteria contained in 3.1.10.2(a), (b), and (c) are also applicable to grade A items.

**3.1.10.2 Grade B items.** Grade B items shall withstand shock tests conducted in accordance with this specification without creating a hazard (see 6.6.6) to personnel or to grade A equipment. Unless otherwise specified (see 6.2) the following shock test acceptance criteria shall apply to grade B items:

- (a) The shock tested item, portions thereof, or the contents thereof shall not come adrift due to exposure to shock. Exceptions to this criterion, which shall be approved by the acceptance authority on a case basis, will be acceptable in cases where it can be demonstrated that the weight, shape, and all other characteristics of the item which has come adrift are such as to preclude a significant impact threat to personnel or adjacent grade A items.
- (b) Injurious, flammable, radioactive, acidic, caustic, or otherwise hazardous liquids, solids or gases shall not be released as a result of exposure of the tested item to shock. Exceptions to this criterion, which shall be approved by the acceptance authority on a case basis, will be considered in cases where it can be demonstrated that the nature, location, rate, or total possible amount of leakage is such as to prevent development of a significant threat to grade A systems, personnel, or to the ship as a whole. In addition, and for purposes of this criterion, any fluid whose operating temperature is above 150 degrees Fahrenheit (F) or below 0F shall be considered hazardous. Fluids at any temperature shall be regarded as hazardous if they might cause an electrical short.
- (c) Tested items shall not demonstrate a potential for fire hazards. Any evidence of electrical shorts, release of flame, smoke or sparks shall be cause for

## MIL-S-901D (NAVY)

rejection of the tested item, unless otherwise specifically approved by the acceptance authority on a case basis.

- (d) It is not required that grade B items be operable after shock testing.

3.1.10.2.1 Supplemental grade B acceptance criteria. Grade B shock test acceptance criteria, in addition to those listed above, may be specified if necessary to suit specific or unusual applications (see 6.2).

3.1.11 Resolution of shock test failures. In cases where shock testing causes damage or malfunctions which violate shock test acceptance criteria, the contractor shall perform repeat shock tests in accordance with the following to resolve the failure:

- (a) In cases where corrective design modifications would be confined to subsidiary components or subassemblies of the tested item, the contractor may recommend, for acceptance authority approval, that only the affected subsidiary components or affected subassemblies be subject to repeat testing. Acceptance authority approval to proceed in this manner will be contingent upon demonstration by the contractor that such tests can be conducted in a manner which realistically represents conditions and loadings experienced by the affected subsidiary component or subassembly during the original shock test, and that modifications made to the affected subsidiary component or subassemblies will not serve to reduce the shock resistance of those portions of the originally tested item which are not subject to repeat testing. In order to permit convenient retesting of the item, if retesting is required by the acceptance authority, resolutions of acceptability of the proposed procedure shall be accomplished, if possible, before removal of the tested item from the test facility.
- (b) In cases where repeat testing in accordance with 3.1.11(a) is not considered appropriate for lightweight or medium weight tests, the lightweight or medium weight test series shall be repeated to verify the adequacy of corrective design modifications.
- (c) In cases where repeat testing in accordance with 3.1.11(a) is not considered appropriate for

## MIL-S-901D(NAVY)

heavyweight tests, the following criteria shall apply to repeat testing to verify the adequacy of corrective design modifications:

- (1) Shot 1 shall be repeated before continuing the test series if damage in violation of acceptance criteria is discovered after any shot of the test series.
- (2) Shot 4 shall be repeated if damage in violation of acceptance criteria occurs during that shot. Damage occurring during shots 2 or 3 and discovered prior to the conduct of shot 4 will not necessitate repeat of shots 2 and 3, unless the damage is related to operating conditions represented only during those shots. Damage in violation of acceptance criteria shall be corrected before proceeding to the next shot of the test series unless otherwise approved by the acceptance authority.
- (3) In cases where shock test damage in violation of acceptance criteria is not discovered until post-test teardown or until conduct of post-test operational tests, shot 1 and shot 4 shall be repeated. If the damage is possibly related to operating modes represented only during shots 2 and 3, these shots shall also be repeated.
- (4) Selection of heavyweight test shots to be repeated, and procedures for such tests, shall be recommended by the contractor and approved by the acceptance authority prior to performing the repeat tests.

3.1.12 Shock test reporting. When required by the contract or order, shock test reports for all items shock tested in accordance with this specification shall be prepared (see 6.2.2).

3.1.13 Acceptance of shock tested items. The format shown on figure 19 shall be used by the acceptance authority to convey shock test approval information to the contractor. The information shown on figure 19 shall be forwarded by the approval authority to all parties which received copies of the shock test report.

3.1.14 Disposition of shock tested items. Upon completion of shock test activities, shock tested grade A items shall normally be delivered for use aboard ship after reconditioning and

## MIL-S-901D (NAVY)

refurbishment as necessary to assure compliance with all applicable pre-delivery requirements. Applicable acquisition documents may specify specific requirements for supplemental pre-delivery testing or examination of all shock tested items, or may require disposal of the tested item in the manner specified (see 6.2.1). Shock tested valves shall not be installed in any ship as sea valves or hull penetrations. Shock tested resilient mountings shall not be installed in any ship.

3.1.15 Use of Government-owned shock test facilities. Unless otherwise specified by the contracting activity (see 6.2.1), shock tests shall be conducted at commercial test facilities. If a Government facility is requested, a request shall be prepared (see 6.2.2).

3.2 Extension of previous shock test approvals. In cases where acquisition documents require that the item being acquired comply with the shock testing requirements of this specification, this requirement may be satisfied by demonstrating that previously conducted and approved shock tests apply to the item being acquired and provide a basis for acceptance of the item. Requirements applicable to extension of previous shock test approvals are contained in 3.2.1 through 3.2.2.1.

3.2.1 General. General criteria applicable to shock test extension shall be as follows:

- (a) Shock test extension policies apply to items identical or similar to previously shock tested and approved items, and to items identical to those previously approved on the basis of shock test extension.
- (b) Lightweight and heavyweight shock tests previously conducted and approved in accordance with previous issues of this specification may be cited as a basis for shock test extension, irrespective of differences between this issue and previous issues of this specification.
- (c) Medium weight shock tests previously conducted and approved in accordance with previous issues of this specification may be cited as a basis for shock test extension irrespective of differences between this issue and previous issues of this specification, with the exception that previous shock testing shall have included (or been supplemented by) testing in two directions as required by 3.1.8.2. Inclined tests performed on the fixture shown on figure 18 or similar

## MIL-S-901D(NAVY)

double-angle fixture will be accepted in lieu of two separate inclined tests (see 3.1.6.2.3).

- (d) Shock test extensions applicable to principal units shall be based primarily upon previous tests of similar or identical principal units; it shall not be acceptable to base shock test extensions of principal units solely upon previous tests of subsidiary components or subassemblies. Similarly, shock test extensions applicable to subsidiary components shall not be based solely upon previous shock test of assemblies.
- (e) Design or service differences (if any) between the new item and the originally tested and approved items shall be limited in scope and extent such that the effect of these differences upon shock resistance can be accurately evaluated on an engineering basis. In all cases where differences exist between new items and previously approved items, it shall be shown that the new items possess equal or greater shock resistance than the originally tested items.
- (f) Damage, malfunction, or degradation of performance noted in the shock test report for the previously tested item, if accepted without corrective action or accepted with corrective action unconfirmed by retesting, shall be specifically evaluated for acceptability in the new item or new application.
- (g) The new item shall be shown to be no more susceptible to shock-induced malfunctions than the originally shock tested and approved item. Only malfunctions which would lead to violation of shock test acceptance criteria need be considered. Such malfunctions could, for example, include shock induced actuation of latches, switches, relays, circuit breakers, or alarms.
- (h) The shipboard mounting location, orientation, and dynamic characteristics intended for the new item shall be no more severe from a shock standpoint than the mounting location, orientation and dynamic characteristics represented during the original shock test. The shock test extension criteria contained in table III shall be applied to determine the acceptability of new shipboard mounting locations and orientations.

## MIL-S-901D (NAVY)

- (i) Class II equipment test approvals shall not be extended to cover class I applications. Unless otherwise specified (see 6.2.1), class I equipment shock test approvals shall not be extended to cover class II applications, except as noted in 3.1.6.3(e).
- (j) In cases where subsidiary components or subassemblies which were not represented during the original shock tests are added to the new item, or in cases where new subsidiary components or subassemblies are substituted for those represented during the original shock test, evidence shall be provided to show that the new subsidiary components or subassemblies are in compliance with the other requirements of this specification.
- (k) The overall effect upon shock resistance of adding or substituting subsidiary components or subassemblies as described in 3.2.1(j) shall be evaluated. For instance, if a new subassembly heavier than the one represented during previous shock testing of a principal unit is to be substituted, the effect of this added weight upon the shock resistance of the new principal unit shall be evaluated in accordance with 3.2.1(a) through 3.2.1(p).
- (l) Shock test extension of an item produced by a given manufacturer shall not be based upon previous shock testing of an item produced by a different manufacturer except where specifically allowed for 'build-to-print' type acquisitions (see 6.2.1).
- (m) Items previously shock tested and approved on the basis of grade B requirements shall not be extended to grade A applications, unless it can be demonstrated that the previous test and subsequent inspections demonstrated compliance with grade A requirements in all respects. Previous shock tests of grade A items may be cited as a basis for extension to grade B applications.
- (n) In order for a previous shock test extension approval to be cited as a basis for further extension to new applications, the following criteria shall be met:
  - (1) The new item and the item previously approved on the basis of a shock test extension shall be identical in design.

## MIL-S-901D (NAVY)

- (2) If the original extension approval was based upon medium weight shock testing, the requirements of 3.2.1(c) shall apply.
  - (3) New applications of the item shall be no more demanding or severe from a shock standpoint than applications covered by the original shock test extension approval; the criteria presented in 3.2.1(f), 3.2.1(h), 3.2.1(i), and 3.2.1(l) shall apply to comparisons of new and original applications.
- (o) In cases where brittle materials (any material with an elongation capability of less than 10 percent) must be utilized in the new item in areas where fracture would violate shock test acceptance criteria, it shall be shown that these materials possess equal or better fracture toughness than those in corresponding locations of the originally approved item, and that shock loading of parts composed of such materials in the new item will be no more severe than experienced during shock tests by corresponding parts of the originally approved item.
  - (p) Applicable acquisition documents may contain additional requirements applicable to shock test extension of specific items (see 6.2.1).

3.2.2 Shock test extension requests. When appropriate (see 3.2.1) or when required by the contract or order, requests for approval of items on the basis of shock test extension shall be prepared (see 6.2.2).

3.2.2.1 Acceptance of shock test extension requests. The format shown on figure 19 shall be used to convey shock test extension approval information to the contractor. The information shown on figure 19 shall be forwarded to all parties which received copies of the shock test extension request.

3.3 Equipment and drawing marking.

## MIL-S-901D(NAVY)

TABLE III. Mounting limitations for shock test extension.<sup>1</sup>

Shock category of original shock test <sup>2</sup>	Test fixtures used during original shock test	Acceptable new shipboard mounting locations <sup>4</sup>	Acceptable new shipboard mounting orientations <sup>5</sup>
Lightweight	Standard <sup>3</sup>	Hull, deck	All
	Nonstandard <sup>3</sup>	Deck <sup>6</sup>	
Medium weight	Standard <sup>3</sup>	Hull, deck	7
	Nonstandard <sup>3</sup>	Deck <sup>6</sup>	
Heavyweight	Deck-type (see 3.1.6.3(c))	Deck	7
	Hull-type (see 3.1.6.3(f))	Deck	
	Shell-type (see 3.1.6.3(i))	Deck, hull	
	Wetted-surface type (see 3.6.1.(g) and 3.1.6.3(h))	Wetted-surface	

<sup>1</sup> Acceptable new shipboard mounting plane (see 1.2.6 same as represented during the original test.

<sup>2</sup> See 1.2.1.

<sup>3</sup> Standard test fixtures are those identified as such by 3.1.6.1, 3.1.6.2.1, and 3.1.6.2.2. Other test fixtures are nonstandard.

<sup>4</sup> See 1.2.5.

<sup>5</sup> See 1.2.7.

<sup>6</sup> Hull mounted locations will be also acceptable unless the nonstandard fixture was specifically designed to simulate deck-type conditions.

<sup>7</sup> Same as represented during the original test.

## MIL-S-901D (NAVY)

3.3.1 Drawings. When the contract or order specifies preparation or updating of drawings associated with equipment for which this specification is invoked, then the Government will require that the information specified in 3.3.1.1 through 3.3.1.4 be incorporated on an appropriate drawing, preferably the general assembly drawing, as a part of the required preparation or update task.

3.3.1.1 For items approved on the basis of shock testing. The following information shall be added on the assembly drawings:

- (a) Shock test category (see 1.2.1).
- (b) Shock grade (see 1.2.2).
- (c) Equipment class (see 1.2.3).
- (d) Shock test type (see 1.2.4).
- (e) Mounting location aboard ship (see 1.2.5).
- (f) Mounting plane aboard ship (see 1.2.6).
- (g) Mounting orientation aboard ship (see 1.2.7).
- (h) Applicable shock test report.
- (i) Approval letter reference.

3.3.1.2 For items approved by extension of previous shock test approvals. The following information shall be added on the assembly drawings:

- (a) Shock test category (see 1.2.1).
- (b) Shock grade (see 1.2.2).
- (c) Equipment class (see 1.2.3).
- (d) Shock test type (see 1.2.4).
- (e) Mounting location aboard ship (see 1.2.5).
- (f) Mounting plane aboard ship (see 1.2.6).
- (g) Mounting orientation aboard ship (see 1.2.7).
- (h) Applicable shock test report on which extension is based.
- (i) Extension approval letter reference.

3.3.1.3 Limitations. If limitations have been placed upon application of the item by the letter approving the shock test or the shock test extension, these limitations shall also be noted on the assembly drawings of the items.

3.3.1.4 Resilient mountings. Resilient mountings used during the shock tests of the item shall also be specifically identified in the drawing notes (see 3.4).

3.4 Marking of equipment requiring resilient mountings. When use of resilient mountings between equipment and ship structure (or foundation) is required for class II or class III equipment, the

## MIL-S-901D(NAVY)

National Stock Number (or commercial designator if no National Stock Number is applicable) of the required mounting shall be indicated on the equipment. The marking shall be accomplished by a separate identification plate conforming to MIL-P-15024 and MIL-P-15024/5. This marking shall read as follows:

"Mounting No. (or commercial designator) \_\_\_\_\_  
only must be used to mount this equipment."

## 4. QUALITY ASSURANCE PROVISIONS

4.1 Responsibility for inspection. Unless otherwise specified in the contract or purchase order, the contractor is responsible for the performance of all inspection requirements (examinations and tests) as specified herein. Except as otherwise specified in the contract or purchase order, the contractor may use his own or any other facilities suitable for the performance of the inspection requirements specified herein, unless disapproved by the Government. The Government reserves the right to perform any of the inspections set forth in the specification where such inspections are deemed necessary to ensure supplies and services conform to prescribed requirements.

4.1.1 Responsibility for compliance. All items shall meet all requirements of sections 3 and 5. The inspection set forth in this specification shall become a part of the contractor's overall inspection system or quality program. The absence of any inspection requirements in the specification shall not relieve the contractor of the responsibility of ensuring that all products or supplies submitted to the Government for acceptance comply with all requirements of the contract. Sampling inspection, as part of manufacturing operations, is an acceptable practice to ascertain conformance to requirements, however, this does not authorize submission of known defective material, either indicated or actual, nor does it commit the Government to accept defective material.

4.2 Shock test facilities. Shock tests performed in accordance with this specification shall be conducted at an approved shock testing facility. A listing of approved shock testing facilities may be obtained from the Naval Sea Systems Command (Ship Protection Division). Shock machines or floating shock platforms not referred to in this listing shall be inspected by the designated Government representative (see 6.6.9) and certified by the test agency and the designated Government representative to the Naval Sea Systems Command (Ship Protection Division) to be constructed and installed in accordance with the drawings referenced herein prior to acceptance of items shock tested at these facilities.

## MIL-S-901D(NAVY)

4.3 Number of items requiring tests. Shock test approval shall be based upon shock testing of a single item unless otherwise specified (see 6.2.1). Acquisition documents may require periodic shock testing of items from different manufacturing lots, particularly when the shock resistance of such items is unusually sensitive to minor variations in workmanship or construction.

4.4 Shock test report witness and certification requirements (see 6.6.7 and 6.6.8). When specified in the contract or order, performing activities shall certify and prepare information (see 6.2.2). This information shall also be certified by the designated Government representative in accordance with the following (see 6.6.9):

- (a) For heavyweight tests, the designated Government representative shall witness the shock test, the actual post-test inspection and functional tests, and shall certify reported shock test, post-test inspection, and functional test information.
- (b) For lightweight and medium weight tests, the designated Government representative shall certify reported shock test, post-test inspection, and functional testing information, when specified in the contract or order (see 6.2.2) and whenever the shock tests, associated shock test inspections, or functional tests are witnessed by a Government representative. Unless otherwise specified (see 6.2.1), the Government representative is not required to witness light-weight or medium weight shock tests, associated post-test inspections, or functional tests. (Guidance for Government representatives: It is expected, at a minimum, that designated Government representatives will witness shock tests, associated shock test inspections, and functional tests on a sampling basis at all activities performing under a given contract. Tests and inspections of relatively complex or high-value items should normally be witnessed.)
- (c) When specified in the contract or order, the contractor shall prepare advance notice of shock test and post-test inspection schedules, as necessary, (see 6.2.2) to permit the designated Government representative to make arrangements for witnessing these events.

## MIL-S-901D (NAVY)

## 5. PACKAGING

This section is not applicable to this specification.

## 6. NOTES

(This section contains information of a general or explanatory nature that may be helpful, but is not mandatory.)

6.1 Intended use. This specification covers shock tests used to verify the ability of shipboard machinery, equipment, systems, and structures to withstand shock loadings which may be incurred during wartime service due to the effects of nuclear or conventional weapons.

6.1.1 Limitations. This specification is very general in its coverage since it is applicable to all shipboard items which are subject to these shock testing requirements. Accordingly, this specification does not provide the complete, detailed shock test requirements which are applicable to any specific item (see 3.1.1). In the event that acquisition documents do not specify all detailed requirements needed to define an acceptable shock test, the contractor must develop these requirements as required by 3.1.1.1 herein.

6.2 Acquisition requirements. Acquisition documents must specify the following:

- (a) Title, number, and date of this specification.
- (b) Issue of DoDISS to be cited in the solicitation, and if required, the specific issue of individual documents referenced (see 2.1).
- (c) Applicable shock grade (see 1.2.2 and 3.1.3).
- (d) Equipment class (see 1.2.3 and 3.1.4).
- (e) Shock test type (see 1.2.4, 3.1.5, and 3.1.5.3). If type B tests are required because the principal unit is too large or too heavy to permit shock testing, also describe how the principal unit shall be broken down into shock-testable groups of subsidiary components (see 3.1.2(c) and 3.1.5.2).
- (f) Equipment mounting location aboard ship (see 1.2.5).
- (g) Equipment mounting plane aboard ship (see 1.2.6).

## MIL-S-901D(NAVY)

- (h) Equipment mounting orientation aboard ship (see 1.2.7, 3.1.6.2.3, and 3.1.8.3).
- (i) Method of mounting items for tests. Designate standard test fixtures to be used (see 3.1.6) or describe the design of the required test fixture (see 3.1.6.3). Define requirements, if any, for torquing of hold-down bolts (see 3.1.6.3(k)).
- (j) Method of simulating shipboard connections (see 3.1.7.1).
- (k) Modes or conditions of equipment operation to be represented during tests (energized, de-energized (or both), pressurized, rated speed, temperatures, or other operating conditions). For lightweight shock test, state the operating condition to be represented during each of the series of nine blows (see 3.1.8.1 and 3.1.8.4). For medium weight shock tests, state the operating mode to be represented during group I and III blows, and the operating mode or modes to be represented during group II blows (see 3.1.8.2 and 3.1.8.4). For heavyweight shock tests, state the operating mode to be represented during each test shot (see 3.1.8.3 and 3.1.8.4).
- (l) Shock test acceptance criteria and associated post-test functional testing and inspection requirements. In accordance with 3.1.10.1, define minimum acceptable performance of grade A items during and following shock tests, such as extent of momentary malfunction if permitted and degree of permanent functional impairment allowed. State requirements applicable to important characteristics such as alignment, dielectric strength, and pressure-tight integrity. Furnish supplemental grade B acceptance criteria if applicable (see 3.1.10.2 and 3.1.10.2.1). Identify requirements for monitoring equipment during tests and for functional testing and inspection after tests (see 3.1.8.5, 3.1.9, and 3.1.10.1(b)) as required to demonstrate compliance with acceptance criteria.
- (m) Acceptance authority or authorities (see 6.6.3).

6.2.1 Supplemental ordering data. The following ordering data or any portion thereof may be specified in addition to the acquisition requirements of 6.2 in cases where the contracting

## MIL-S-901D(NAVY)

requirements of this specification. Unless otherwise specified, the contractor is not required to develop supplemental ordering data for acceptance authority approval if such data is not furnished by applicable purchase documents.

- (a) Shock test category or limitations upon selection of shock test category (see 1.2.1, 3.1.2, and 3.1.2(d)).
- (b) Requirements for acceptance authority approval of acquisition requirements of 6.2 developed by the contractor for lightweight or medium weight shock tests (see 3.1.1.2).
- (c) Permission or requirements to utilize the large floating shock platform or other Government-owned shock test facilities (see 3.1.2(c), 3.1.6.3(h), and 3.1.15).
- (d) Additional requirements for selection of standard test fixtures or for design of non-standard test fixtures by the contractor, including specific criteria to simulate shipboard mounting conditions (see 3.1.6.3(c) and 3.1.6.3(j)).
- (e) Permission to shock test class III items in the rigidly mounted configuration only (see 3.1.6.3(e)).
- (f) Specific requirements for weight or design of dummy masses (see 3.1.7.1(a)).
- (g) Permission or requirements to simulate one or more of a group of identical subsidiary components or subassemblies (see 3.1.7.2 and 3.1.7.3).
- (h) Requirements for heavyweight shock test shots at standoffs greater than shot 1 standoff (see 3.1.8.3).
- (i) Specific requirements for partial simulation of operating conditions during shock tests in cases where it is not practical to fully simulate shipboard operating conditions (see 3.1.8.4(e)).
- (j) Additional limitations upon allowable loosening of fasteners (see 3.1.8.6).
- (k) Special post-shock test noise and vibration criteria (see 3.1.10.1(e)).

## MIL-S-901D(NAVY)

- (l) Requirements for supplemental pre-delivery testing or examination of shock tested items (see 3.1.14).
- (m) Requirements for disposition of shock tested items (see 3.1.14).
- (n) Use of alternate Government owned shock test vehicles (see 3.1.2(d)).
- (o) Additional criteria applicable to shock test extension (see 3.2.1(g), 3.2.1(h), 3.2.1(i), 3.2.1(k), 3.2.1(l) and 3.2.1(p)).
- (p) Requirements for marking of drawings when different than specified in 3.3.1.
- (q) Number of articles requiring tests when different than specified in 4.3.
- (r) Requirements for witnessing of lightweight or medium weight shock tests or associated post-test inspections (see 4.4(b)).
- (s) Requirements for additional distribution of high-impact shock test procedures (see 6.3(a)).
- (t) Requirements for additional distribution of shock test reports (see 6.3(b)).
- (u) Requirements for additional distribution of shock test extension requests (see 6.3(d)).

6.2.2 Consideration of data requirements. The following data requirements should be considered when this specification is applied on a contract. The applicable Data Item Descriptions (DID's) should be reviewed in conjunction with the specific acquisition to ensure that only essential data are requested/provided and that the DID's are tailored to reflect the requirements of the specific acquisition. To ensure correct contractual application of the data requirements, a Contract Data Requirements List (DD Form 1423) must be prepared to obtain the data, except where DOD FAR Supplement 27.475-1 exempts the requirement for a DD Form 1423.

## MIL-S-901D (NAVY)

<u>Reference Paragraph</u>	<u>DID Title</u>	<u>DID Number</u>	<u>Option</u>
3.1.1.2, 3.1.8, 3.1.9, 3.1.10.1, and 4.4	High-impact shock test plan or procedures	DI-ENVR-80709	Distribution requirement (see 6.3(a)).
3.1.12, 4.4, 4.4(B) and 3.1.8.6	Shock test report	DI-ENVR-80708	Distribution requirement (see 6.3(b))
3.1.1.2, 3.3.1	Drawings, engineering and associated lists	DI-E-7031	_____
3.1.15	Request for use of Government- owned shock test facilities	DI-ENVR-80707	Distribution requirement (see 6.3(c)).
3.2.2	Shock test extension request	DI-ENVR-80706	Distribution requirement (see 6.3(d)).
4.4(c)	Notification of tests	DI-T-23731	_____
3.1.12 & 3.2.2	Shock qualification data sheet	DI-ENVR-80710	Distribution requirement (see 6.3)

The above DID's were those cleared as of the date of the specification. The current issue of DOD 5010.12-L, Acquisition Management Systems and Data Requirements Control List (AMSDL), must be researched to ensure that only current, cleared DID's are cited on the DD Form 1423.

6.2.2.1 Waiver of data requirements. The data requirements of 6.2.2 and any task in sections 3, 4, or 5 of this specification required to be performed to meet a data requirement may be waived by the contracting/acquisition activity upon certification by the offeror that identical data were submitted by the offeror and accepted by the Government under a previous contract for identical

## MIL-S-901D (NAVY)

item acquired to this specification. This does not apply to specific data which may be required for each contract regardless of whether an identical item has been supplied previously (for example, test reports).

6.2.2.2 Shock qualification. Section 3. 1 specifies shock qualification information which is to be incorporated on a suitable equipment drawing if the contract or order requires development or modification of such a drawing. The data requirement to include this information should be incorporated by the acquisition activity as part of the requirement for the drawing concerned.

6.3 Bid/contract requirements. The following information is provided as guidance concerning requirements to be included in bids or in the contract for the distribution by the contractor of data required by this specification:

- (a) Distribution of shock test procedures should be accomplished as follows:
  - (1) Acceptance authority: Two copies unless otherwise specified (see 6.2.1).
  - (2) Contracting activity: One copy, if contracting activity is not identical to the acceptance authority (see 6.2.1).
  - (3) Manufacturers of items to be tested: In cases where the contractor is not the manufacturer of principal units or subsidiary components to be tested, or is not the manufacturer of a subassembly which is to undergo type C testing, these manufacturers shall be furnished a copy of the shock test procedures for information. Distribution of shock test procedures to manufacturers of subassemblies which comprise subsidiary components or principal units to be tested may be required (see 6.2.1).
  - (4) Naval Sea Systems Command (Ship Protection Division), Washington, DC 20362-5101: One copy for information and one microfiche copy for data storage.
  - (5) Supervisor of Shipbuilding, Conversion and Repair, USN, Brooklyn, NY 11251: One copy for review and one microfiche copy for data storage.

## MIL-S-901D(NAVY)

- (6) Naval Ship Systems Engineering Station (Code 045B), Philadelphia, PA 19112: One copy for information and one microfiche copy for data storage.
  - (7) Performing shock test facility: One copy for information.
  - (8) Other: As specified (see 6.2.1).
- (b) Distribution of shock test reports should be accomplished as follows:
- (1) Acceptance authority: Two copies unless otherwise specified (see 6.2.1). In cases where a local representative of the acceptance authority has certified shock test or post-shock test information, a copy of the report shall also be forwarded to that representative.
  - (2) Contracting activity: One copy, if the contracting activity is not identical to the acceptance authority (see 6.2.1).
  - (3) Manufacturers of tested items: In cases where the contractor is not the manufacturer of tested principal units or subsidiary components, or is not the manufacturer of a subassembly which has undergone type C testing, these manufacturers shall be furnished a copy of the test report for information. Distribution of shock test reports to manufacturers of subassemblies which comprise tested subsidiary components or principal units may be required (see 6.2.1).
  - (4) Naval Sea Systems Command (Ship Protection Division), Washington, DC 20362-5101: One copy for information and one microfiche copy for data storage.
  - (5) Supervisor of Shipbuilding, Conversion and Repair, USN, Brooklyn, NY 11251: One copy for review and one microfiche copy for data storage.
  - (6) Naval Ship Systems Engineering Station (Code 045B), Philadelphia, PA 19112: One copy for information and one microfiche copy for data storage.

## MIL-S-901D(NAVY)

- (7) Performing shock test facility: One copy for information.
  - (8) Other: As specified (see 6.2.1).
- (c) Distribution of requests for use of Government-owned heavyweight shock test facilities should be forwarded via the acceptance authority to the Naval Sea Systems Command (Ship Protection Division). Distribution of requests for use of Government-owned lightweight and medium weight shock test facilities should be forwarded to the test facility with an information copy to the acceptance authority. DI-ENVR-80707 applies.
- (d) Distribution of shock test extension requests should be accomplished as follows:
- (1) Acceptance authority: Two copies unless otherwise specified (see 6.2.1).
  - (2) Contracting activity: One copy, unless otherwise specified (see 6.2.1).
  - (3) Manufacturers of items subject to shock test extension approval: In cases where the contractor is not the manufacturer of the item which is subject to shock test extension approval, the manufacturer shall be furnished a copy of the shock test extension request for information.
  - (4) Naval Sea Systems Command (Ship Protection Division), Washington, DC 20362-5101: One copy for information and one microfiche copy for data storage.
  - (5) Supervisor of Shipbuilding, Conversion and Repair, USN, Brooklyn, NY 11251: One copy for review and one microfiche copy for data storage.
  - (6) Naval Ship Systems Engineering Station (Code 045B), Philadelphia, PA 19112: One copy for information and one microfiche copy for data storage.
  - (7) Other: As specified (see 6.2.1).

## MIL-S-901D(NAVY)

6.4 General information. The following information is provided as guidance for designers and others responsible for fulfilling the provisions of this specification:

- (a) All items will exhibit some deflection during exposure to shock; nothing is "rigid", except in a relative sense.
- (b) To account for relative deflection between components during shock loadings, the designer should endeavor to build maximum tolerance for relative motion between component parts into his design. Examples of relative motion-tolerant design are:
  - (1) Maximized clearances between rotating and nonrotating parts.
  - (2) Design such that momentary impact between rotating and nonrotating parts will not significantly affect equipment performance.
  - (3) Provision of sufficient slack in wiring to prevent pull-out or breaking of wires during shock excursions.
  - (4) Stiffened or braced structure and avoidance of designs and structural arrangements (such as cantilevered elements) which tend to deflect excessively.
  - (5) Provision of ample clearance between separately-mounted components or equipments to prevent shock-induced impact.
  - (6) Design of control systems such that shock-induced relative motions do not cause significant false signals to be introduced into control system logic.
  - (7) Design of systems utilizing limit switches on safety tripout devices such that shock-induced relative motions will not cause inadvertent shock-induced shutdown of vital equipment.
  - (8) Use of flexible shaft couplings, flexible waveguide sections, and flexible tubing or piping loops where necessary to accommodate relative motion.

## MIL-S-901D (NAVY)

- (9) Avoidance of requirements to rigidly connect items to two elements of ship structure which could deflect relative to each other during shock loadings.
- (c) Desirable material properties for shock resistant design are high yield strength, high ductility (at least 10 percent elongation), high fracture toughness, and, in some cases, low density (to reduce inertial forces). Undesirable material properties are brittleness, low impact resistance, high nilductility transition temperature, and high notch sensitivity. Cast iron and cast aluminum have proven generally unsatisfactory when used in strength members in shock resistant applications. Use of these materials as strength members in shock resistant applications may be prohibited by separately invoked specifications.
- (d) In general, ample cross-sections should be provided in potentially highly-stressed areas, and factors causing stress concentrations, such as notches or sudden changes of cross-section, should be avoided. Structural continuity should be achieved whenever practical, with aim of distributing shock-induced stresses throughout structures in a reasonably uniform manner.
- (e) Well-constructed positive securing means such as hinges or shafts with bearings should be utilized instead of knife-edge pivots in the design of support of moving parts of mechanisms such as voltage regulators and relays.
- (f) Levers, linkages, and other moving parts of mechanisms should be dynamically balanced (either individually or on a system basis) whenever practical in order to reduce the likelihood of shock-induced malfunction. This criterion is particularly applicable to items such as circuit breakers, rotary solenoids, relays, governor systems or other control systems, and emergency shut down systems.
- (g) Cantilevered mounting of equipments or components should be avoided; experience indicates that this method of mounting commonly leads to excessive deflections, high stresses, and consequently to shock test failures and shipboard vibration problems.

## MIL-S-901D (NAVY)

- (h) Friction cannot be depended upon as a means for maintaining the relative position of alignment-sensitive components during exposure to shock, regardless of the apparent static holding power of the frictional connection. Positive locating and holding means such as fitted bolts or rabbetted joints should be utilized in alignment critical applications. Positive means should also be used for securing tapered dowels and similar items in lieu of relying upon friction alone as a means for securing such devices. Positive locking devices should be used to prevent wires, circuit boards, etc., from loosening from connections.
- (i) Electronic cabinets and other items which are designed to facilitate quick maintenance access or removal must have positive, shock resistant means for latching, secure closure, lock-in, or support when in their normal operating position. Such latching or locking devices should be quickly and easily operated and should not require special tools. For example, use of one or two single-turn positive latches to secure an electronics cabinet drawer sliding assembly is the preferred approach; use of ten capscrews to accomplish the same function is discouraged.
- (j) Where bolts (including cap screws, machine screws, and studs) are installed in clearance holes, the clearance should be minimized to cause proper sharing of bolt shear loads and to reduce the adverse effects of impacting due to load reversals under shock. The following clearance criteria are recommended (and may be invoked as a requirement by applicable specifications):

<u>Nominal bolt diameter</u>	<u>Maximum diameter of hole</u>
3/4 inch and smaller	Nominal bolt diameter plus 1/32 inch
Larger than 3/4 inch	Nominal bolt diameter plus 1/16 inch

- (k) Where alignment must be maintained, fitted bolts or other positive methods should be used. Nearly all bolted joints tend to loosen under shock. Proper bolt design, sufficient pre-stress, and adequate finishing and sizing of joint surfaces can eliminate or reduce this tendency. For joints employing O-rings or other

## MIL-S-901D (NAVY)

types of gaskets, proper bolt pre-stressing is essential to prevent the flanges from momentarily parting under shock with possible displacement of the gasket due to the internal hydrostatic forces.

- (l) In general, where required by separately invoked specifications, bolts should be tightened (pre-stressed) to a maximum value consistent with the allowable stress, the effects of combined loads, and operating conditions. Lock nuts may help to preserve the initial pre-stressing and will normally assist in minimizing the possibility of additional damage in the event the joint does become loose following shock loadings. Except for very light items such as gauges, mounting bolts less than 1/2 inch in diameter should not be used because of the inherent risk of over stressing during initial or subsequent tightening. Reduced shank or hollow bolts increase the capability of the bolt to absorb energy; however, in order to maintain tight and unseparated joints, it is preferable in almost every case of bolted joint design to transmit energy rather than attempt to absorb it.
- (m) When possible, locate welded joints away from highly stressed areas. The effects of stress reversals should be considered in joint selection. For instance, welds loaded only in compression under normal conditions will experience both tensile and compressive loadings in the shock environment. Weld design should make allowance for corrosion, difficulty in welding, discontinuities and other factors which tend to reduce weldment strength. The effect of heat on the material as a result of welding, especially for aluminum and similar materials, should be determined and allowed for. In general, 100 percent efficient joint designs should be used to develop strength needed to resist shock loadings. The ability to perform weld inspections satisfactorily should be considered in the design of joints. Experience indicates that a seemingly disproportionate number of shock test failures have been caused by improper selection of welding procedures or by lack of effective production quality control in this area.
- (n) Threaded pipe and fittings should be avoided. Where threaded connections cannot be avoided, flexibility should be provided to minimize the load on the

## MIL-S-901D (NAVY)

threads. Flexibility should be provided in piping runs between different components or where they are attached to structures that can have relative movement under shock. The inertial effects of piping can be large, and sufficient support should be provided so as not to over-stress or elastically deform the equipment or associated valves or fittings excessively. Shock test requirements for piping system components for Naval shipboard use are specified in MIL-STD-798.

- (o) Subject to limitations which may be separately specified, shock mounts may be employed, based on a definite need, and only after a careful review of the design indicates that it is not otherwise feasible to meet the shock requirements. Where a need for shock protection is established, the mount characteristics should be determined based on a knowledge of the particular shock environment and the dynamic nature of the equipment. Mounts must also be compatible with other shipboard environments such as vibration and service conditions and, as such, may be separately required to meet the requirements of MIL-M-17185.
  
- (p) Most resilient mountings intended primarily to serve as noise or vibration isolating devices possess non-linear characteristics, and the load mitigating properties under normal environmental loadings often change radically with the large amplitudes and high rates of loading encountered in the shock environment. Mount deflection under shock, especially for base mounted equipment, should be considered when specifying the clearances around the equipment and in the design of waveguide, piping, and similar continuous systems. All mountings should have a positive, mechanical captive feature in their design. Resilient mounts originally designed for the purpose of mitigating shipboard or equipment noise or vibration do not necessarily possess good shock mitigation properties, and on many occasions have proven detrimental in the shock environment owing to hard bottoming of the mounts or due to the introduction of resonance problems which in effect cause the mounting system to amplify shock motions. For these reasons, and because resilient mounting systems necessarily demand weight, space (clearance), and maintenance requirements in excess of corresponding rigidly mounted arrangements, the application of resilient mounts is commonly

## MIL-S-901D (NAVY)

- restricted by applicable specifications.
- (q) Design of items for resistance to the adverse effects of vibration will normally also enhance shock resistance. It is particularly important in both shock and vibration-resistant applications to avoid structural resonance between small components and large masses in the same (attached) system, and to use positive securing means for the item and its components. Shock-induced vibratory amplitudes and associated absolute displacements are normally much greater than those associated with normal vibration environments.
- (r) It should not be automatically assumed by the designer that standard-line equipment must be redesigned in order to satisfy the requirements of this specification. Standard-line (or commercial) items have often passed the shock tests required by this specification because:
- (1) The item tested was originally designed to withstand high operating loads (internal pressure, tensile or torsional loads, etc.) and thus is inherently resistant to shock loadings also.
  - (2) The item will remain functional despite minor shock-induced distortion of structural members or internal parts. (Grade A shock test acceptance criteria are normally keyed to the ability of tested items to function properly during and after exposure to shock, rather than to the physical condition of items following shock tests).
  - (3) Separately invoked or self-imposed requirements intended to provide resistance against shock loadings caused by handling or shipping of items have caused ruggedness to be built into the design.
- (s) Information concerning shock test devices and tested equipment response is available from Naval Research Laboratory, Structural Integrity Branch, Washington, DC 20375. Additional information concerning the construction and characteristics of floating shock platforms is available from Underwater Explosions Research Division, David Taylor Research Center, Portsmouth, VA 23709.

## MIL-S-901D(NAVY)

- (t) Design provisions to limit the extent or effect of momentary malfunctions under shock (e.g., redundant contacts) will depend to some extent on the design of the system in which a component is intended to be used. Examples of momentary malfunctions (see 3.1.10.1(d)) and the considerations affecting their acceptability include the following:
- (1) Loss of suction: Acceptable for bulk liquid transfer pumps, bilge stripping pumps, fire pumps, lube oil pumps, and similar pumps, provided that the interrupted pressure or flow from the pump returns to normal without manual actions and resumes quickly enough to avoid wiped bearings, upset of fluid control systems, etc. This same malfunction is unacceptable for items such as control oil pumps where falling control oil pressure causes a manual-reset trip valve to close, fuel oil pumps where the interruption may be long enough to extinguish burner flames, pumps where manual action to reprime the suction or stop the pump is necessary to prevent pump damage, and in similar cases.
  - (2) Lifting of relief valves: Acceptable if the valve reseats without assistance with normal system pressure maintained at the inlet piping to the valve, provided no hazard is created by valve effluent. Unacceptable if the valve fails to reseat without assistance, if effluent could cause a hazard, or if the valve is tested with equipment incapable of sustaining a prolonged (several seconds) normal lift and reseat of the valve.
  - (3) Interruption of instrument reading: Acceptable for basic gauges whose readings are taken manually, provided no manual protective action or automatic securing of the equipment would result from the interrupted reading. Unacceptable for instruments monitored by automatic control systems where loss of instrument reading, false reading, or loss of sensor signal causes an automatic protective action.
  - (4) Governor/regulator control signal fluctuation: Acceptable only if the specified characteristics of the equipment being controlled are known and the fluctuation of control signal can be shown to

## MIL-S-901D (NAVY)

result in a change in the parameters of the equipment being controlled that is small enough to be acceptable. Unacceptable if the control signal fluctuation results in controlled equipment parameters outside the acceptable range (e.g., excessive or inadequate speed, frequency, voltage, pressure, etc., resulting in damage or interrupted operation of the controlled item or downstream equipment dependent on the output of the controlled item).

- (5) Contact bounce, trip, or change of state: Contact bounce in relay, switch, or circuit breaker contacts is acceptable only as defined by the applicable acquisition documents. Shock-induced bounce of contacts not designed for opening or closing under load (e.g., disconnect devices) is unacceptable. Shock-induced tripping of grade A circuit breakers or change of state of grade A switches is unacceptable. If no requirements for contact bounce are set forth in applicable acquisition documents, then bounce-open of closed contacts is acceptable only if self-correcting and brief enough that no impairment of downstream equipment results, while bounce-closed of open contacts is unacceptable.
- (6) Loss of program or data: Loss of program or stored data is unacceptable. Momentary loss of data being received or transmitted is acceptable provided it is automatically detected and corrected without significant impact on communications link capacity or on controlled functions dependent on the transmitted data.

6.5 Items requiring Government approval. The attention of those responsible for the preparation of acquisition documents is invited to the items listed below which, in all cases, require approval of the Government (Command, Agency, Activity, or its designated representative). To minimize requirements for separate Government approval action, contract ordering data should include information related to the items listed below, whenever possible. Note that additional requirements for Government approval of information related to shock testing may be added to the contract ordering data if deemed necessary.

- (a) Ordering data for heavyweight tests when independently developed by the contractor (see 3.1.1.2).

## MIL-S-901D(NAVY)

- (b) Ordering data for lightweight and medium weight shock tests when independently developed by the contractor, when required by 6.2.1 or when submitted by the contractor (see 3.1.1.2).
- (c) Permission to utilize the large floating shock platform (see 3.1.2(c)).
- (d) Permission to accept tested items based upon grade B requirements, if shock grade is not specified (see 3.1.3).
- (e) Permission to perform type B test when recommended by the contractor (see 3.1.5.2).
- (f) Permission for repeat shock testing of subsidiary components or subassemblies only (see 3.1.5.2(b), 3.1.5.3, and 3.1.11(a)).
- (g) Permission to perform type C test (see 3.1.5.3).
- (h) Permission to use nonstandard test fixtures for lightweight tests (see 3.1.6.1).
- (i) Permission to use nonstandard mounting fixtures for medium weight tests (see 3.1.6.2).
- (j) Permission to mount bulkhead-mounted items upon the standard mounting platform, inclined ninety degrees relative to the shipboard mounting position, for medium weight athwartship direction tests (see 3.1.6.2.2(c)).
- (k) Acceptance of test fixture yielding or cracking during shock tests (see 3.1.6.3(d)).
- (l) Permission to simulate one or more of a group of identical subsidiary components in the test of a principal unit (see 3.1.7.2).
- (m) Permission to simulate subassemblies during type A and B tests (see 3.1.7.3).
- (n) Approval of modification of the basic shock test parameters (see 3.1.8).
- (o) Approval to substitute separate items for items which have been exposed to six (or more) medium weight shock

## MIL-S-901D (NAVY)

- (p) Approval of selection of heavyweight test operating modes (see 3.1.8.4(d)). NOTE: This information should normally be included in the heavyweight test ordering data referred to in 6.5(a).
- (q) Approval of functional performance testing to be accomplished after disassembly or repair of the item (see 3.1.9.1).
- (r) Approval of exceptions to standard shock test acceptance criteria (see 3.1.10.2(a), 3.1.10.2(b), and 3.1.10.2(c)).
- (s) Permission to proceed to next shot of the heavyweight test series without correction of damage in violation of acceptance criteria (see 3.1.11(c)(2)).
- (t) Selection of heavyweight test shots to be repeated and procedures for such tests (see 3.1.11(c)(4)).
- (u) Approval of shock test reports (see 3.1.12 and 3.1.13) and DI-ENVR-80707.
- (v) Permission to utilize Government-owned shock test facilities (see 3.1.15).
- (w) Permission for shock test extension of an item produced by a given manufacturer to be based upon previous shock testing of an item produced by a different manufacturer for "build-to-print" type acquisitions (see 3.2.1(1)).

6.6 Definitions. Definitions of terms used herein are as indicated in 6.6.1 through 6.6.9.

6.6.1 Item. Item is defined as a complete and definable unit or a component of machinery, equipment, system, or structure. An item can be a principal unit, subsidiary component, or subassembly. An item can also be a group of units or a system.

6.6.2 System. System is defined as an arrangement or combination of items, all of which are necessary to perform a specific operational function or functions (such as a main propulsion system, a refrigeration system, fire control system, or hydraulic system).

## MIL-S-901D(NAVY)

6.6.3 Acceptance authority. Acceptance authority is defined as the Government activity (or its designated Government representative) having approval authority where approval of actions or results is required herein, and having the responsibility and authority to determine contractor compliance with the requirements of this specification. The acceptance authority for each contract or order will be as specified (see 6.2). Different acceptance authorities may be specified for the various approval actions required herein for a single contract or order.

6.6.4 Contracting activity. Contracting activity is defined as the activity having authority and responsibility to initiate purchase orders, agreements, or documents for acquisition of services, materials, or items.

6.6.5 Contractor. Contractor is defined as a party who has entered into a formal agreement to provide the services, materials, or items specified herein.

6.6.6 Hazard. An item constitutes a "hazard" if, as result of shock it is possible for it, or a portion of it, to:

- (a) Strike and injure personnel operating or manning grade A equipment.
- (b) Strike and cause significant impairment or malfunction of grade A items or systems.
- (c) Cause an electrical short (as a result of internal damage or as a result of coming adrift and striking an electrical conductor) in any electrical system which is not protected by grade A circuit breakers.
- (d) Cause an electrical short which could possibly result in loss of electrical power to a grade A system, cause functional impairment of a grade A system, or cause ignition of flammable or explosive materials.
- (e) Cause release of injurious, flammable, radioactive, acidic, caustic, or otherwise hazardous liquids, solids, or gases, except where it can be demonstrated that the nature, location, rate, or total possible amount of leakage is such as to prevent development of a significant threat to grade A systems, personnel, or to the ship as a whole. Any fluid whose operating temperature is above 150°F or below 0°F should be considered hazardous. Fluids at any temperature should be regarded as hazardous if they might cause an

## MIL-S-901D (NAVY)

electrical short.

- (f) Affect electrical, hydraulic, water, or any other services required by a grade A system to the extent that significant impairment or malfunction of the grade A system might result. Examples of adverse effects: unacceptable variation or unacceptable reduction of pressure, flow rate, or voltage; leakage of a fluid from a non-vital system which could quickly deprive a grade A system of that required fluid.

6.6.7 Witness. Witness is defined as the observer (or observance) of a shock test procedure, post-test inspection, or functional test. It does not imply acceptance of the adequacy or the results of the procedures, tests, or inspections.

6.6.8 Certification. Certification is defined as verification of the accuracy of reported information of shock tests, post-test inspections, and functional tests. It does not imply acceptance of the adequacy or results of the procedures, tests, or inspections. The term is also defined as the verification that a shock test machine or floating shock platform is constructed and installed in accordance with the drawings referenced herein.

6.6.9 Designated Government representative. Designated Government representative is defined as a representative of the Government agency specified in the acquisition document to witness or certify shock test procedures, post-test inspections or functional tests. The term is also defined as the representative of the Government agency specified by the Naval Sea Systems Command to inspect shock test machines or floating shock platforms or to certify them to be constructed and installed in accordance with drawings referenced herein.

6.6.10 Reviewer's signature. This handwritten signature on figure 19 is the reviewer's individual verification and certification of the following facts: (1) that this approval action is based on personal review of the subject test report or test extension request; (2) that this review has considered all shock approval criteria and shock guidance provided by this document, other acquisition documents, current shock policy instructions, and the reviewer's past experience and knowledge; and (3) that the remarks and limitations shown on figure 19 include statements or references to (a) any shortcomings in equipment performance discovered during shock testing, and (b) the extent, if any, to which testing could not be made fully representative of shipboard operating conditions.

MIL-S-901D(NAVY)

6.7 Subject term (key word) listing.

Deck mounted equipment  
Heavyweight shock test  
Hull mounted equipment  
Lightweight shock test  
Medium weight shock test  
Principal unit  
Shell mounted equipment  
Shock  
Subassembly  
Subsidiary component  
Wetted-surface mounted

6.8 Changes from previous issue. Asterisks are not used in this revision to identify changes with respect to the previous issue due to the extensiveness of the changes.

Review activities:  
Navy - AS, EC, MC, OS

Preparing activity:  
Navy - SH  
(Project ENVR-N010)

MIL-S-901D(NAVY)

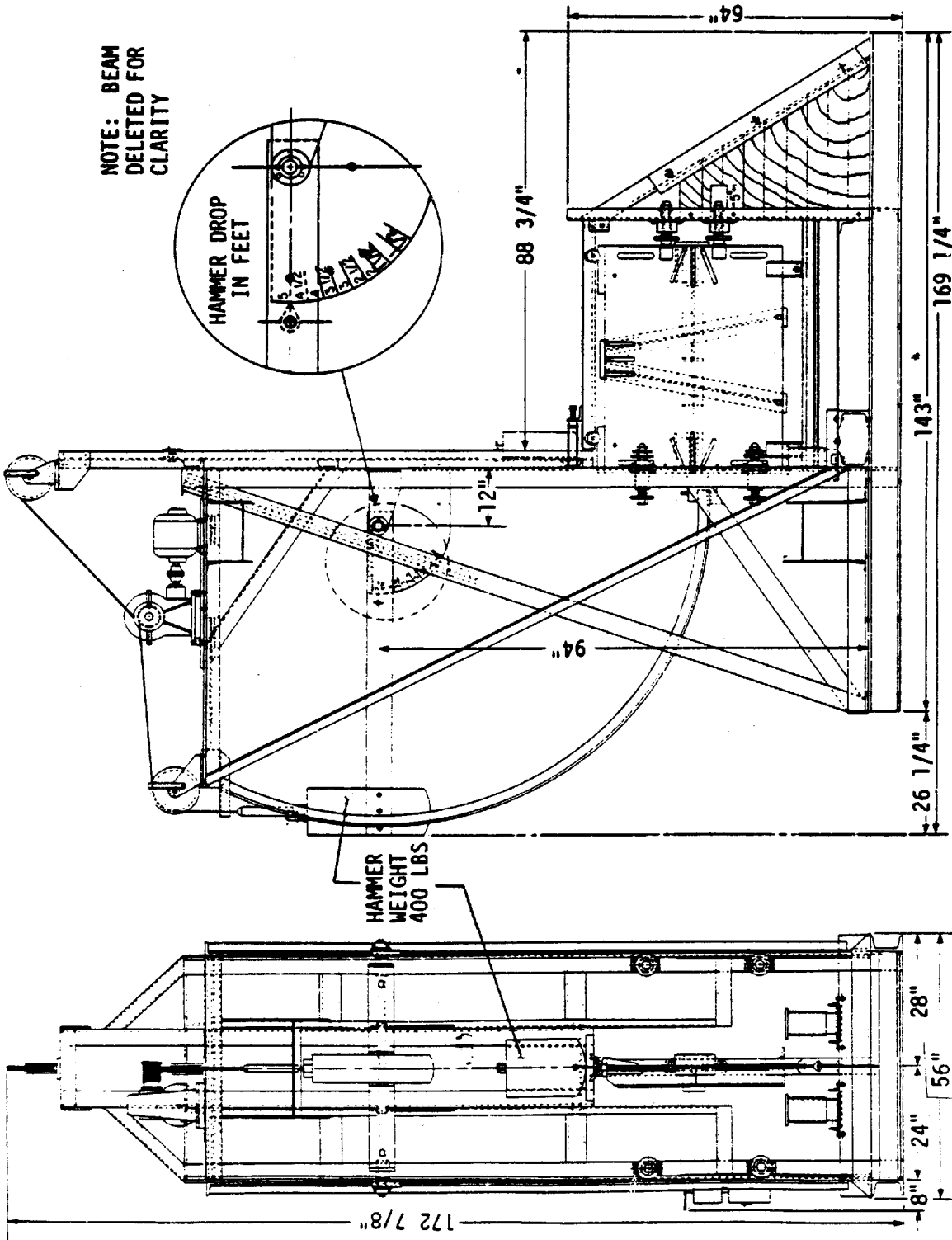
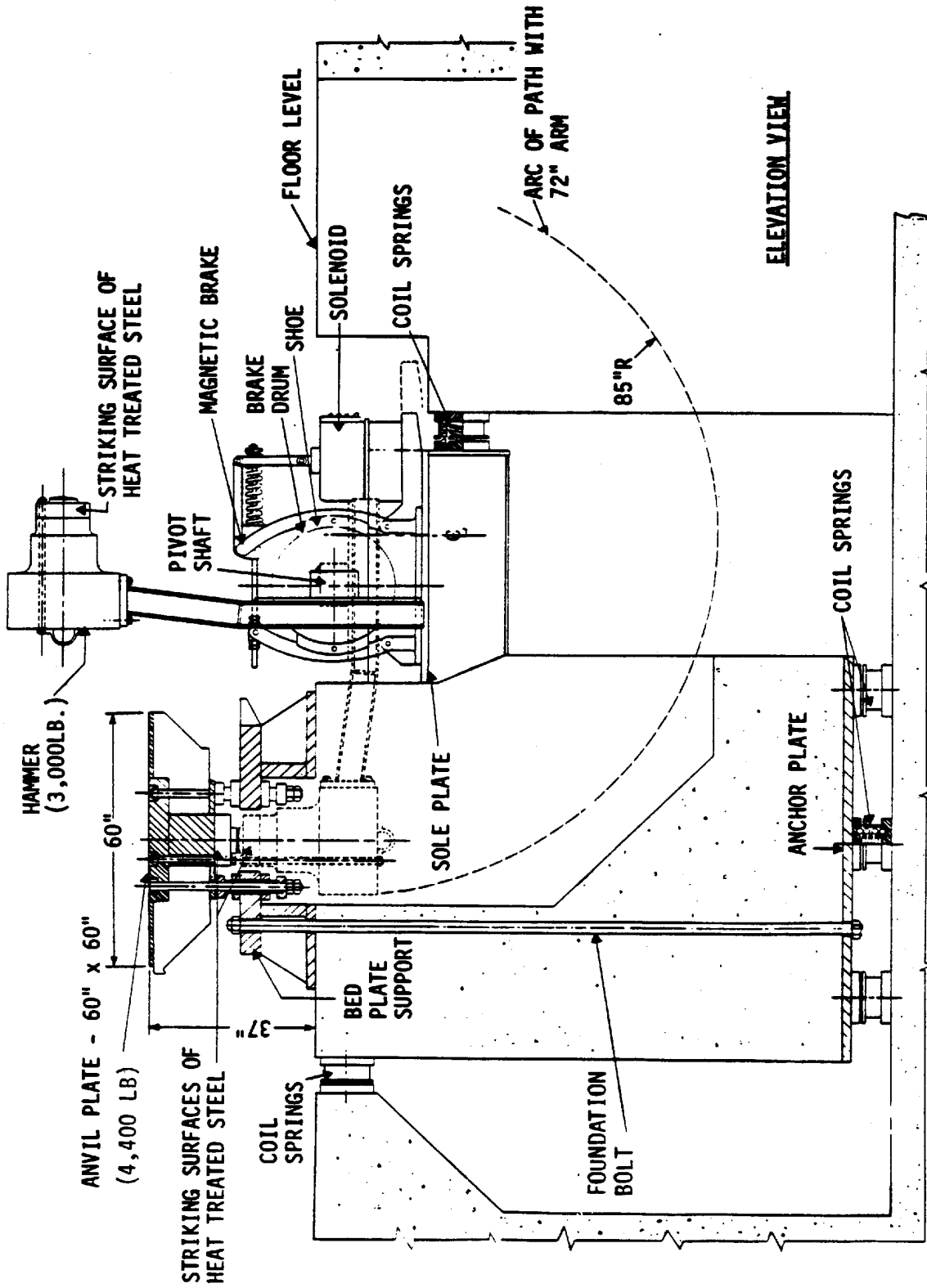

FIGURE 1. Shock testing machine for lightweight equipment. For details of construction, see BUSHIPS drawing 10-T-2145-L.

SH 132031639

MIL-S-901D(NAVY)



SH 132031640  
FIGURE 2. Typical Class HI (high impact) shock testing machine for mediumweight equipment (see BUSHIPS drawing N0807-655947 for construction details).

MIL-S-901D(NAVY)

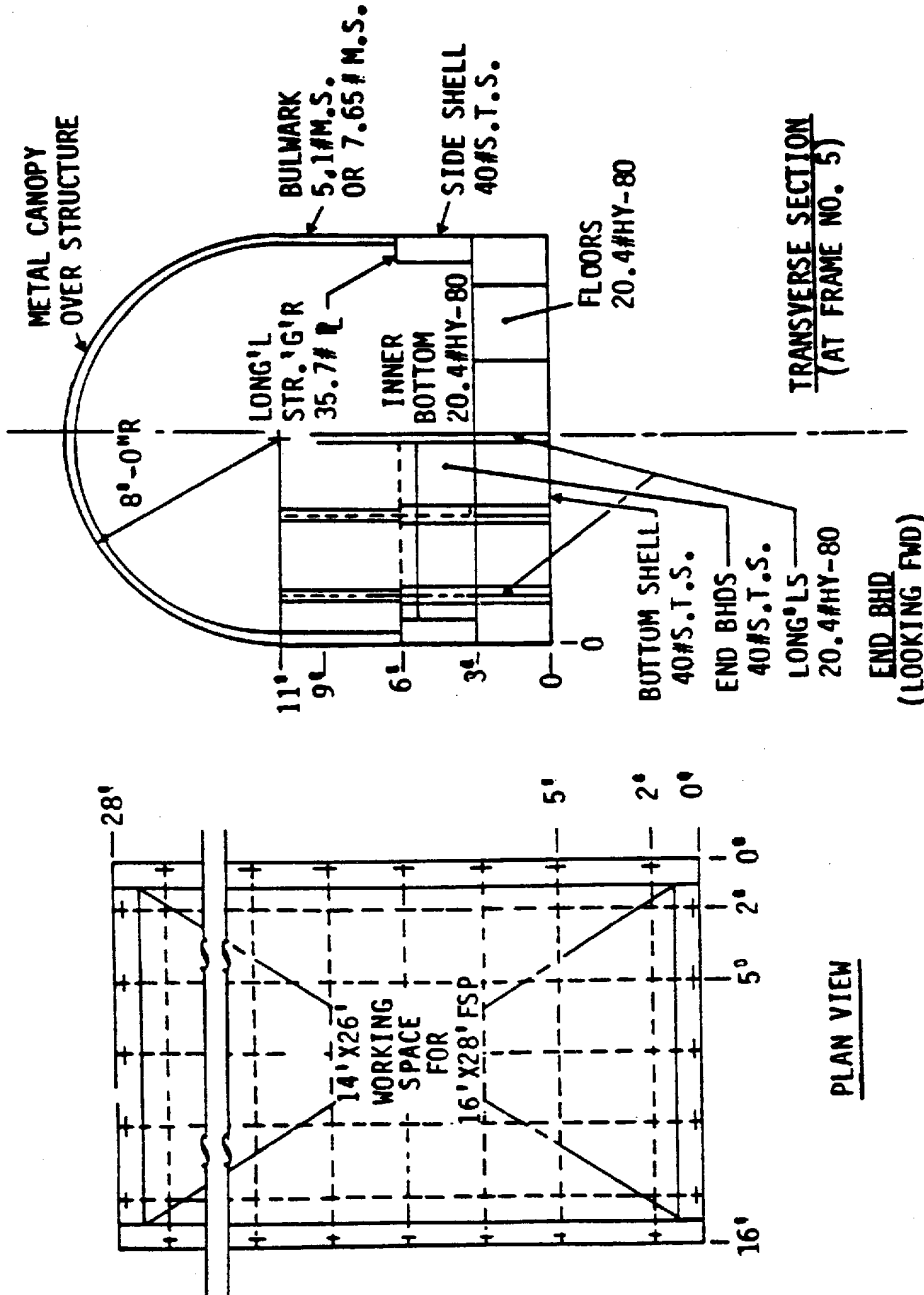

- NOTES:
1. SOME FLOATING SHOCK PLATFORMS ARE 22 FEET LONG RATHER THAN 28 FEET.
  2. SEE BUSHIPS DRAWING 645-1973904 FOR CONSTRUCTION DETAILS.

SH 132031641 **FIGURE 3. Standard floating shock platform.**

MIL-S-901D(NAVY)

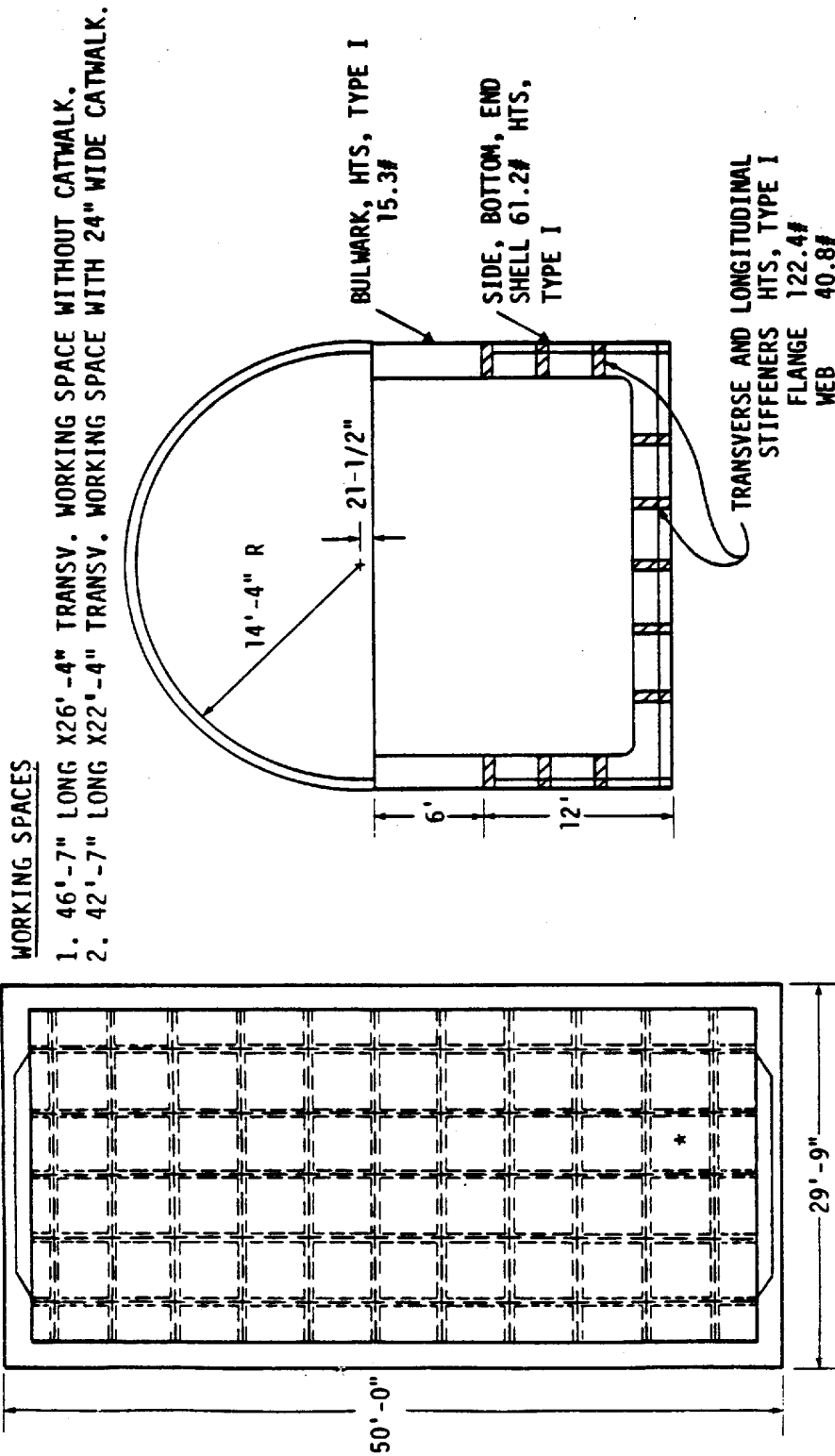

\* NOTE: LFSP HAS NO INNERBOTTOM.

FIGURE 4. Large floating shock platform.

SH 132031642

## MIL-S-901D(NAVY)

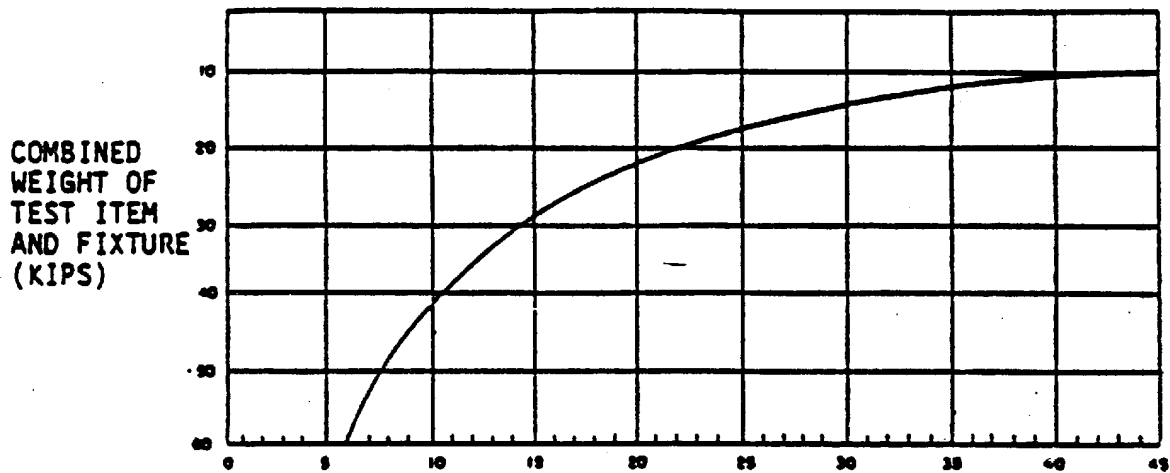

MAXIMUM HEIGHT OF CENTER OF GRAVITY ABOVE PLATFORM MOUNTING SURFACE - FEET

FOR ITEMS MOUNTED BELOW PLATFORM, SEE NOTES 2, 3 AND 4 BELOW.

## NOTES:

1. THIS INFORMATION IS PROVIDED FOR GUIDANCE ONLY AND IS APPLICABLE TO THE 28 FT. STANDARD FLOATING SHOCK PLATFORM (SAN FRANCISCO NAVAL SHIPYARD DWG. SF-645-H-1528).
2. THE MAXIMUM SUGGESTED LOAD LIMIT FOR ALL TESTED ITEMS IS 60,000 LBS FOR ITEMS MOUNTED ABOVE OR BELOW THE PLATFORM. MAXIMUM WEIGHTS INCLUDE WEIGHT OF ITEM, FIXTURE, ANCILLARY EQUIPMENT AND FLUIDS.
3. THE VERTICAL CENTER OF GRAVITY LIMITS ARE SHOWN FOR ITEMS TO BE MOUNTED ABOVE PLATFORM. BOTH WEIGHT AND CENTER OF GRAVITY LIMITS MAY BE EXCEEDED AT DISCRETION OF ITEM SUPPLIER AND SHOCK TEST FACILITY, BUT AN OUTRIGGER MAY BE REQUIRED TO MINIMIZE ROLL.
4. THERE IS NO LIMITATION ON THE VERTICAL CENTER OF GRAVITY FOR TEST ITEMS MOUNTED BELOW THE PLATFORM.
5. THIS CURVE IS BASED ON A TRANSVERSE METACENTRIC HEIGHT OF SLIGHTLY MORE THAN 1.0 FOOT.

SH 132031643

FIGURE 5. Floating shock platform (FSP) — maximum permissible height of vertical center-of-gravity for tested items maximum working area — 14 feet x 26 feet.

## MIL-S-901D(NAVY)

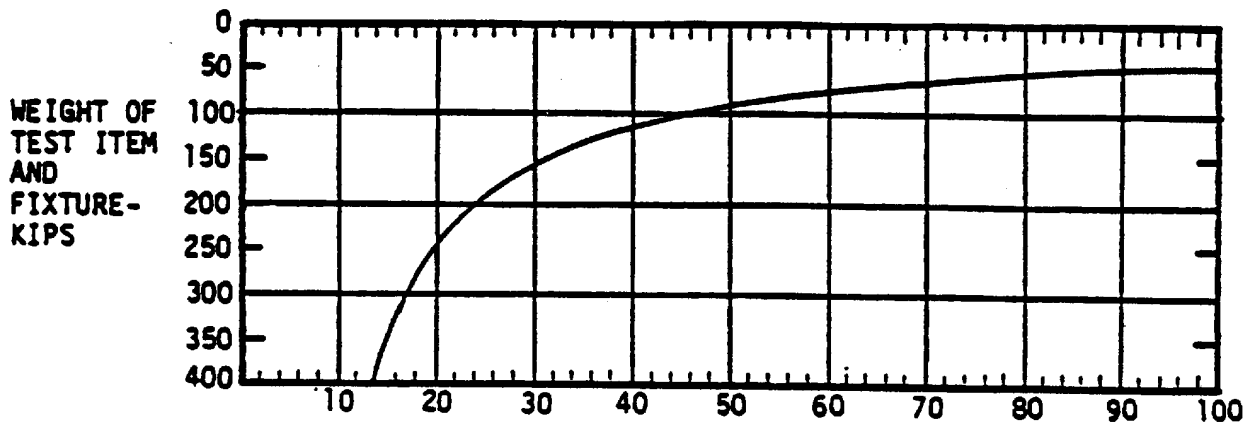

MAXIMUM HEIGHT OF CENTER-OF-GRAVITY ABOVE TOP OF FRAME FLANGES- FEET

FOR ITEMS MOUNTED BELOW PLATFORM, SEE NOTES 2, 3 AND 4 BELOW.

## NOTES:

1. THIS INFORMATION IS PROVIDED FOR GUIDANCE ONLY AND IS APPLICABLE TO THE LARGE FLOATING SHOCK PLATFORM (SAN FRANCISCO NAVAL SHIPYARD DWG. H-81898-SF-645-H1644).
2. THE MAXIMUM SUGGESTED LOAD LIMIT FOR ALL TESTED ITEMS IS 400,000 LBS FOR ITEMS MOUNTED ABOVE OR BELOW THE PLATFORM. MAXIMUM WEIGHTS INCLUDE WEIGHT OF ITEM, FIXTURE, ANCILLARY EQUIPMENT AND FLUIDS.
3. THE VERTICAL CENTER OF GRAVITY LIMITS ARE SHOWN FOR ITEMS TO BE MOUNTED ABOVE PLATFORM. BOTH WEIGHT AND CENTER OF GRAVITY LIMITS MAY BE EXCEEDED AT DISCRETION OF ITEM SUPPLIER AND SHOCK TEST FACILITY.
4. THERE IS NO LIMITATION ON THE VERTICAL CENTER OF GRAVITY FOR TEST ITEMS MOUNTED BELOW THE PLATFORM.
5. THIS CURVE IS BASED ON A TRANSVERSE METACENTRIC HEIGHT OF 2.0 FEET.

FIGURE 6. Large floating shock platform (LFSP) --- maximum permissible height of vertical center-of-gravity for tested items.

MIL-S-901D(NAVY)

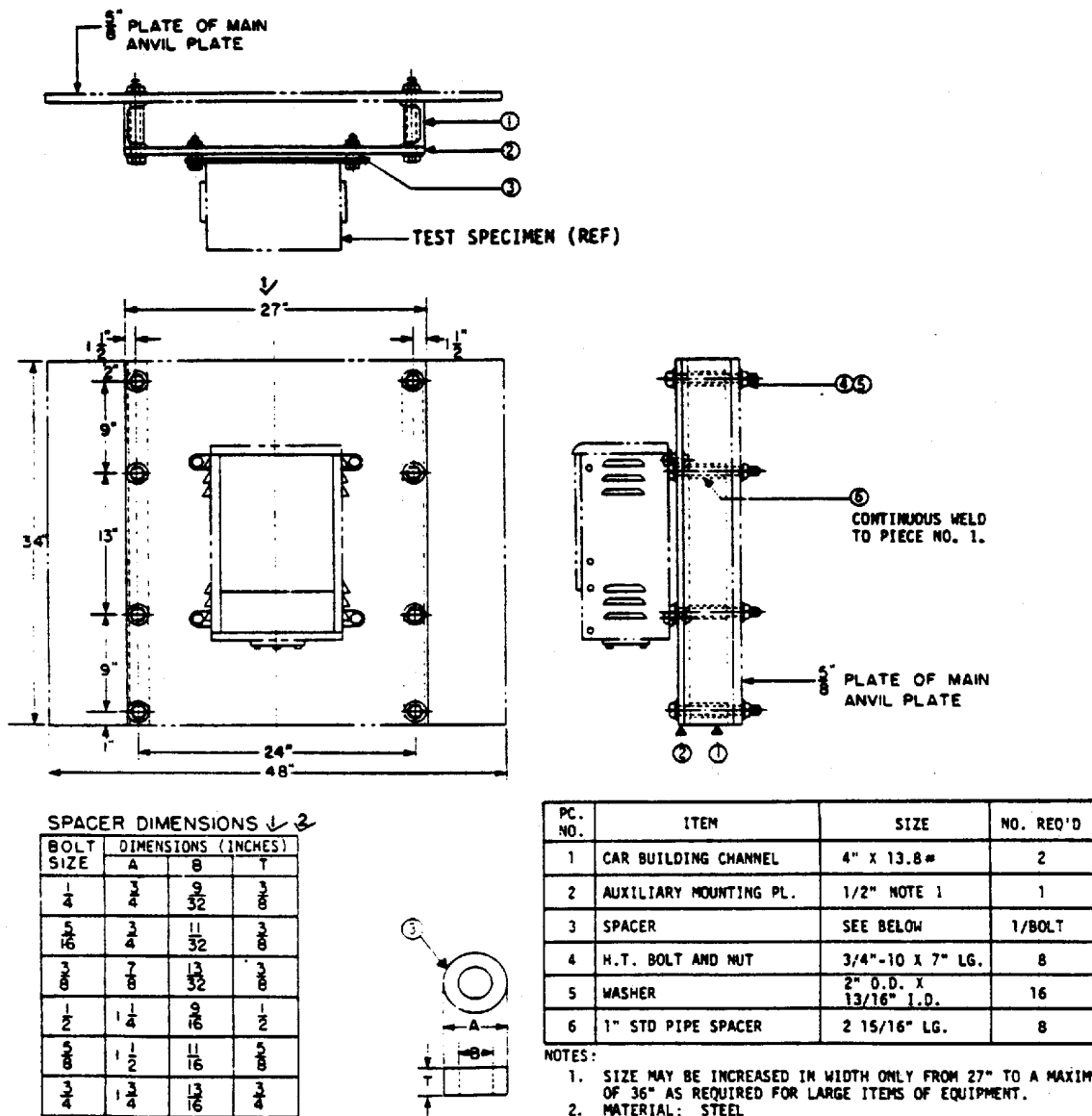

- ✓ SPACERS TO BE USED WHEN SECURING EQUIPMENT TO THE 1/2" AUXILIARY MOUNTING PANEL (PIECE NO 2).
- 2 ONE SPACER SHALL BE USED FOR EACH EQUIPMENT MOUNTING BOLT.

FOR ADDITIONAL DETAILS, SEE BUSHIPS DWG 10-T-2145-L.

SH 132031645

FIGURE 7. Fixture 4A standard mounting for bulkhead mounted equipment (type "A" test LWSM).

MIL-S-901D(NAVY)

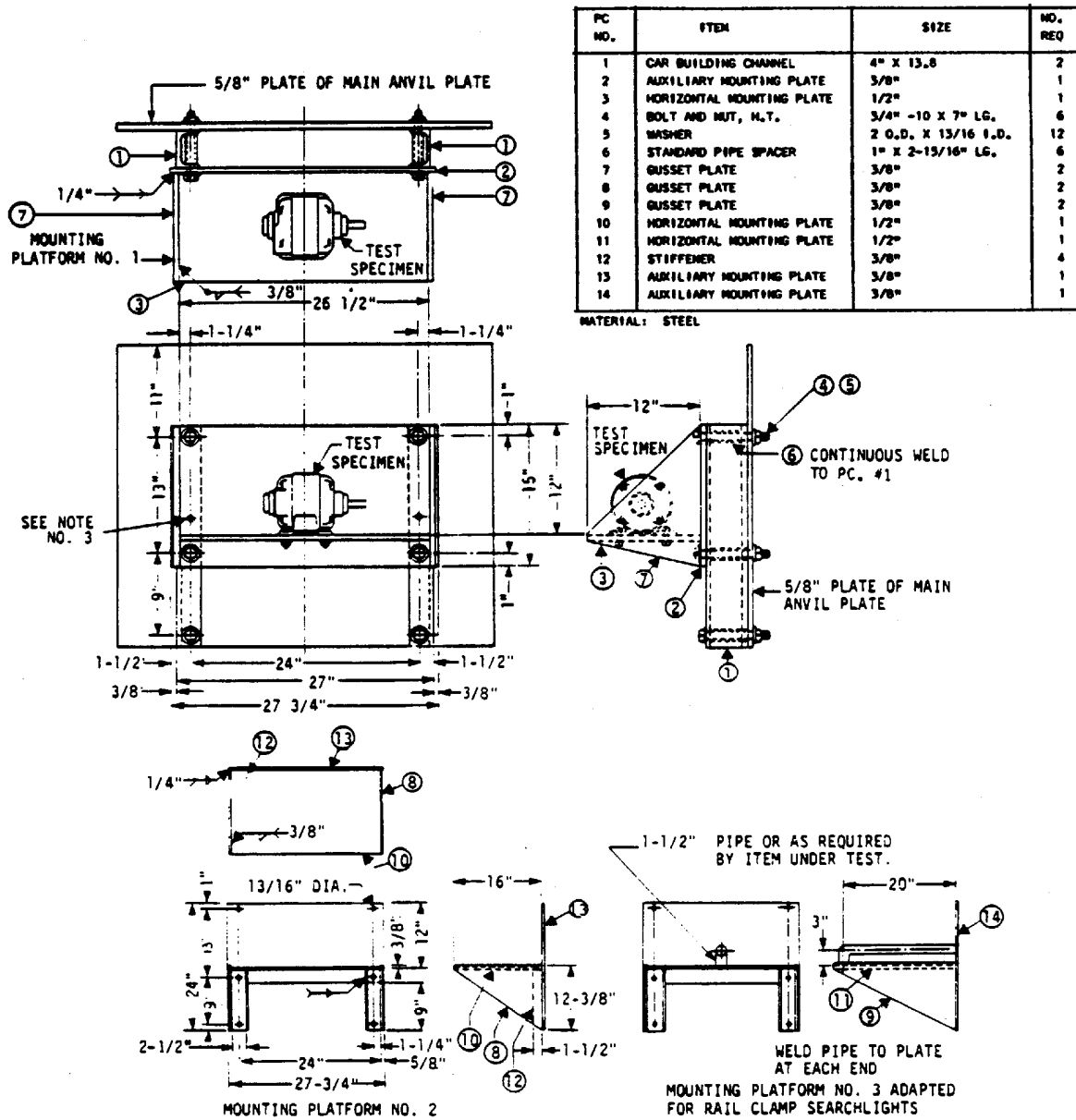

- NOTES:
1. THERE ARE 3 MOUNTING PLATFORMS. MOUNTING PLATFORM NO. 3 SHALL BE SIMILAR TO MOUNTING PLATFORM NO. 2 EXCEPT THAT THE DEPTH OF THE HORIZONTAL MOUNTING PLATE AND THE SIDE GUSSET PLATES SHOULD BE INCREASED TO 22 INCHES.
  2. THE SMALLEST MTG. PLATFORM SHOULD BE SELECTED WHICH WILL SATISFACTORILY ACCOMMODATE THE EQUIPMENT.
  3. IF THE DEEP GUSSETS INTERFERE WITH THE MOUNTING EQUIPMENT, THE EXTRA BOLT HOLES SHOULD BE USED IN BOLTING PLATFORM NO. 1 IN THE INVERTED POSITION TO THE FOUR LOWER BOLT HOLES OF THE ANVIL PLATE.

FOR ADDITIONAL DETAILS, SEE BUSHIPS DWG 10-T-2145-L.

SH 132031646

FIGURE 8. Fixture 4C standard mounting for base mounted equipment (type "A" test LWSM).



MIL-S-901D(NAVY)

PC NO.	ITEM	SIZE	NO. REQ
1	PANEL	1" X 23" X 30"	1
2	STANDARD CHANNEL	3" X 5.0" X 28-1/2"	2
3	FABRICATED SPACER	2-1/2 X 8 X 34	2
4	SPACER STIFFENER	1/4 X 7-1/2 X 2	4
5	BOLT AND NUT	3/4" - 10 X 1-3/4" LG	8
6	WASHER	2" O.D. X 13/16" I.D.	12
7	WASHER	1-3/8" O.D. X 13/16" I.D.	12
8	BOLT AND NUT	1/2" - 13 X 1" LG.	4
9	WASHER	1-3/8" O.D. X 9/16" I.D.	4
10	BOLT AND NUT	3/4" - 10 X 4" LG.	4
11	SPACER	1-1/2 X 2-1/4 X 3-1/2	4
12	STRAP	1/8" X 1"	4
13	BLOCK	2-1/4" X 2" X 1-1/4"	4

MATERIAL: STEEL

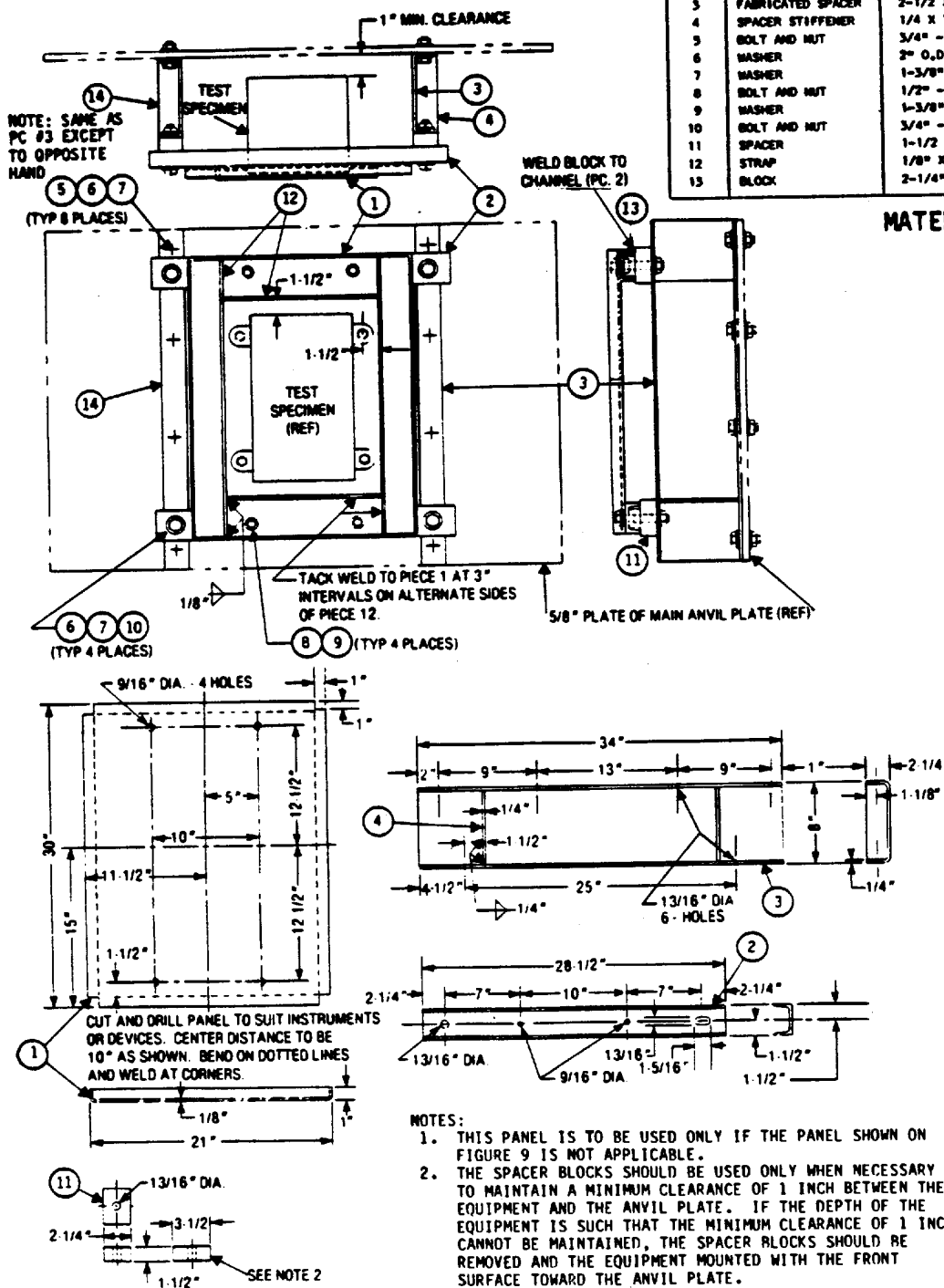

SH 132031648

FIGURE 10. Fixture 6D-2 standard mounting for electrical indicating switchboard meters and other panel mounted equipment (type "C" test LWSM).

MIL-S-901D(NAVY)

PIECE NO.	ITEM	SIZE	NO. REQ'D	MATERIAL
1	CAR BUILDING CHANNEL	4" X 13.8 9	2	STEEL
2	AUXILIARY PLATE ✓	1/2" X 27" X 34"	1	STEEL
3	SPACER	SEE BELOW	—	STEEL
4	PLASTIC MOUNTING PANEL	SEE BELOW	—	LIMITED (MIL-P-19035)
5	BOLT AND NUT	3/4-10 X 7"	8	STEEL (HEAT-TREATED)
6	WASHER	2" O.D. X 13/16" I.D	16	STEEL
7	STANDARD PIPE SPACER	1" IPS X 2-15/16" LG.	8	STEEL
8	MOUNTING HOLE	SEE TABLE		H.T. STEEL

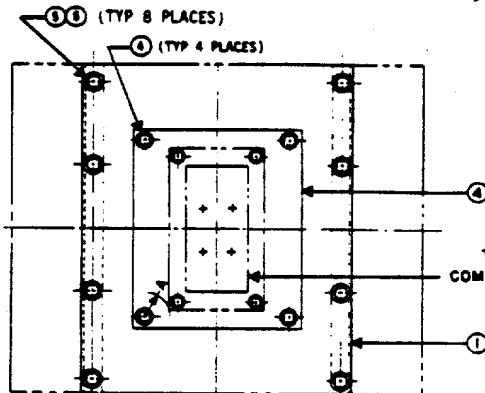
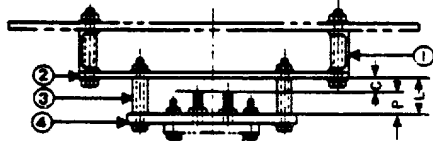

DIMENSION "A", AS MEASURED FROM THE CENTER OF ANY MOUNTING HOLE OF PC. 4 TO THE COMPONENT MOUNTING BASE, SHALL BE NOT LESS THAN 2 1/2 INCHES.

SPACER DETAILS

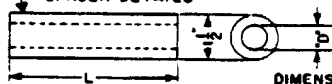

DIMENSION "D" SHALL BE 17/32" FOR 1/2" DIA BOLTS AND 7/32" FOR 3/8" DIA BOLTS.

WHEN P (NOTE ASSEMBLY TOP VIEW) IS:		L	NOTES
LESS THAN	GREATER THAN		
3/4"	—	1 1/2"	
3 1/4"	3/4"	P + 3/4"	
—	3 1/4"	4"	CUT OUT 1/2 INCH THICK AUXILIARY MOUNTING PLATE (PIECE NO 2) TO GIVE 3/4 INCH CLEARANCE AROUND REAR PROJECTIONS

THE SIZE OF THE AUXILIARY PLATE SHOULD BE INCREASED TO 1/2" X 36 X 34 INCHES FOR PANEL NUMBERS 5 AND 6

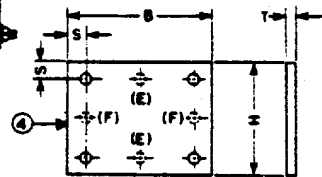
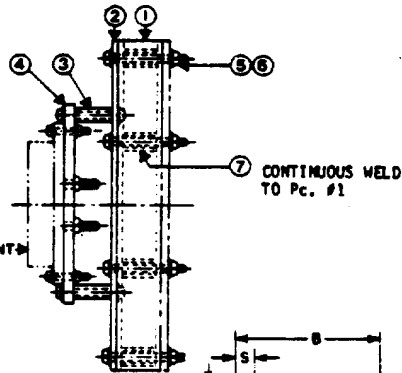

HOLES (E) ARE DRILLED EQUIDISTANT FROM CORNER HOLES ON SAME CENTER LINE-PANEL NO 5 AND 6 ONLY. HOLES (F) ARE DRILLED EQUIDISTANT FROM CORNER HOLES ON SAME CENTER LINE-PANEL NO. 4 AND 6

PANEL NO.	PANEL SIZE (INCHES)				NO. AND SIZE OF BOLTS	DIA OF BOLT HOLES
	B	H	T	S		
1	9	12	3/4	1	4: 1/2"-13	9/16"
2	12	16	1	1	4: 1/2"-13	9/16"
3	16	20	1	1	4: 1/2"-13	9/16"
4	20	24	1	1	6: 1/2"-13	9/16"
5	32	24	1	1 1/4	6: 5/8"-11	11/16"
6	36	34	1	1 1/4	6: 5/8"-11	11/16"

THE PANEL EMPLOYED SHALL BE THE SMALLEST SIZE SHOWN THAT WILL RESULT IN CLEARANCE (NOTE ASSEMBLY FRONT ELEVATION VIEW) OF AT LEAST 2 1/2 INCHES  
 THE MANUFACTURER IS TO PROVIDE THE APPROPRIATE PANEL, TOGETHER WITH ALL SPACERS AND MOUNTING FOR BOLTS, WHEN SUBMITTING A COMPONENT TO A NAVAL LABORATORY FOR TEST

FOR ADDITIONAL DETAILS, SEE BUSHIPS DWG 10-T-2145-L.

SH 132031649

FIGURE 11. Fixture 6E standard mounting for controller components (contactors, relays, resistors, etc.) (type "C" test LWSM).

MIL-S-901D(NAVY)

PC. NO.	ITEM	SIZE	NO. REQ'D
1	CAR BLDG CHAN 4" X 13.8	4" X 13.8	1
2	1/2" AUX MTG PLATE	1/2"	1
3	1/2" HORTZ MTG PLATE	1/2"	1
4	3/4" - 10 X 7" BOLT AND NUT, H.T.	3/4" - 10 X 7" LG.	8
5	WASHER	2" O.D. X 13/16" I.D.	16
6	1" STD. PIPE SPCR	2-5/16" LG.	8
7	GUSSET PLATE	1/2"	3

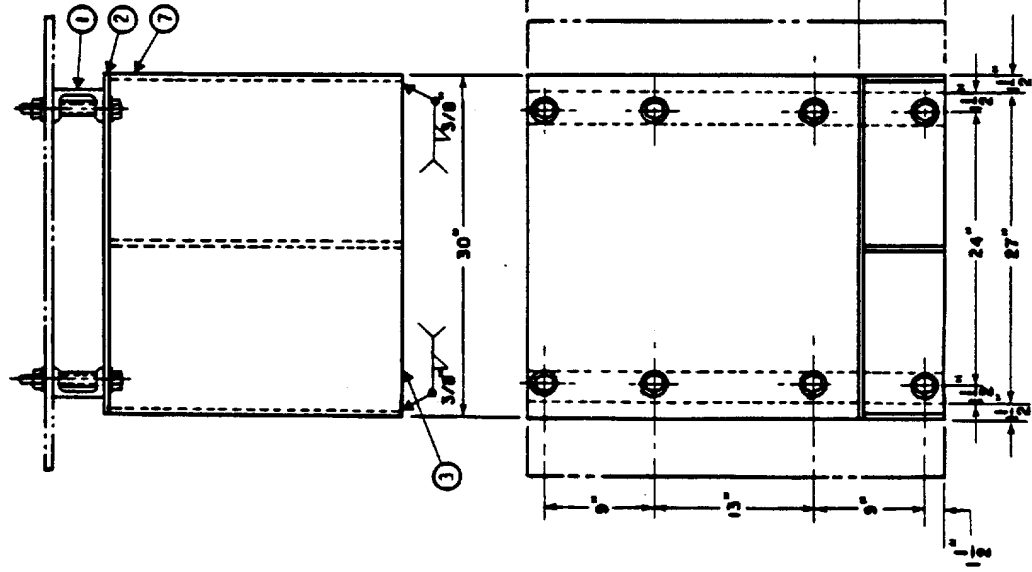

FOR ADDITIONAL DETAILS, SEE BUSHIPS DWG 10-T-2145-L.

SH 132031650

FIGURE 12. Fixture 11C standard mounting for base mounted equipment (lightweight shock machine).

MIL-S-901D(NAVY)

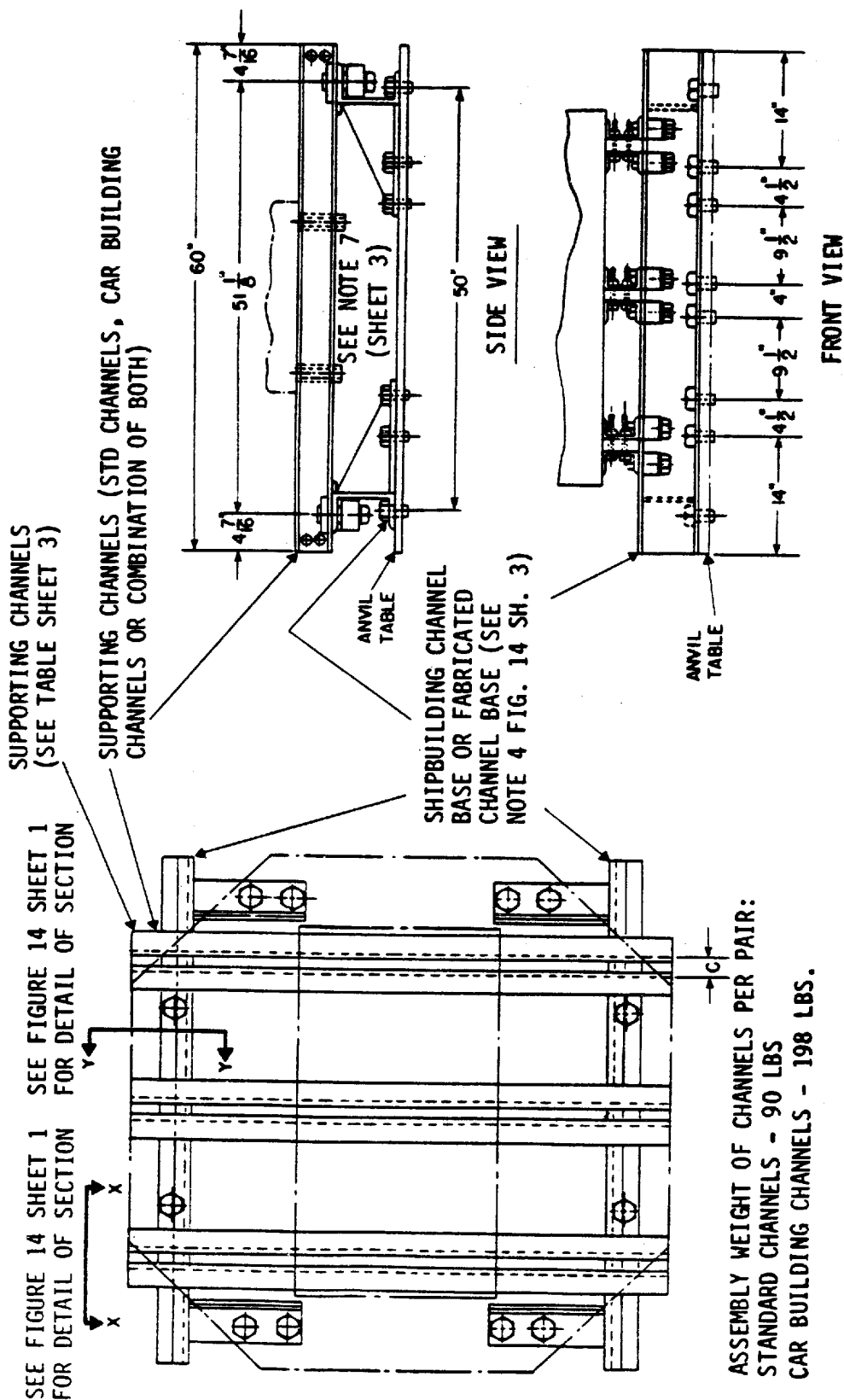
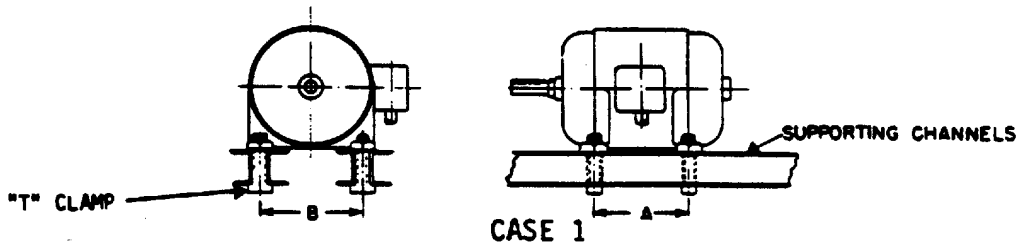

FIGURE 13. Standard mounting platform for testing equipment on mediumweight shock testing machine. (Sheet 1 of 3)

MIL-S-901D(NAVY)

TYPICAL MOUNTING ARRANGEMENTS



CASE 1

FOR EQUIPMENT REQUIRING TWICE THE NUMBER OF SUPPORTING CHANNELS AS THE NUMBER OF PARALLEL LINES OF MOUNTING BOLT HOLES.

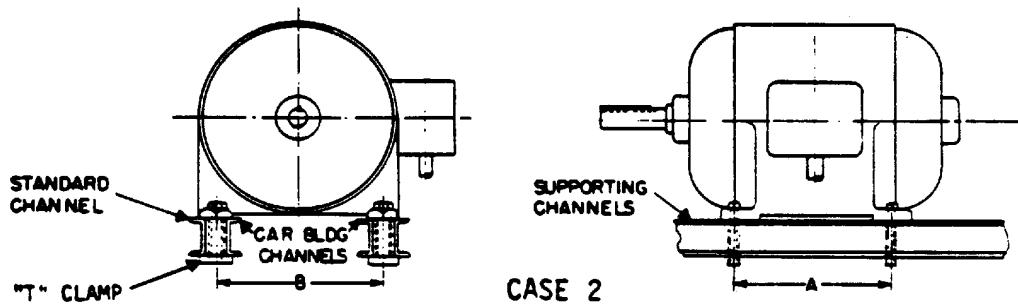

CASE 2  
(SEE NOTE - 10 SHEET 3)

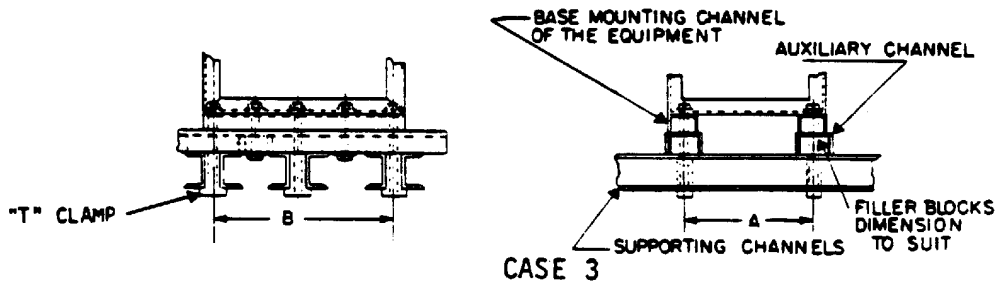

CASE 3

FOR EQUIPMENT REQUIRING FULL SUPPORT ALONG ENTIRE BASE

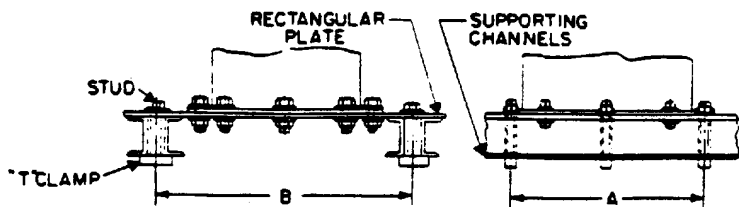

CASE 4  
(SEE NOTE - 11 SHEET 3)

NOTE 1. Cases 1 and 2 illustrate a horizontal shaft, base mounted motor. Vertical shaft motors and motors designed for mounting to a vertical plane shall be tested with their shafts and mounting planes oriented to represent shipboard installation. See 3.1.6.

SH 132031651

FIGURE 13. Standard mounting platform for testing equipment on mediumweight shock testing machine. (Sheet 2 of 3)

MIL-S-901D(NAVY)

NOTES:

1. DIMENSIONS 'A' AND 'B' ARE THE EXTREME BOLT HOLE CENTER DISTANCES OF THE EQUIPMENT WITH DIMENSION 'B' ALWAYS EQUAL TO OR GREATER THAN DIMENSION 'A'
2. THE APPROPRIATE NUMBER OF SUPPORTING CHANNELS SHALL BE SELECTED IN ACCORDANCE WITH THE WEIGHT AND DIMENSION 'A' OF THE EQUIPMENT (SEE TABLE)
3. WHEN SELECTING SUPPORTING CHANNELS FOR WEIGHT AND DIMENSION 'A' NOT LISTED IN TABLE THE NEXT HIGHER WEIGHT VALUE AND THE SMALLER DIMENSION 'A' SHALL BE USED.
4. WHEN SELECTING THE SUPPORTING CHANNELS FOR CASES 3 AND 4 LISTED IN TABLE, THE WEIGHT OF THE AUXILIARY CHANNELS OR PLATES SHOULD BE INCLUDED IN THE EQUIPMENT WEIGHT.
5. TWO STANDARD 4" by 7.25" CHANNELS HAVE A COMBINED STRENGTH EQUIVALENT TO A SINGLE 4" BY 13.8" CAR BUILDING CHANNEL AND MAY BE USED IN PLACE OF OR IN CONJUNCTION WITH, THE CAR BUILDING CHANNELS.
6. WHEN USING STANDARD OR CAR BUILDING CHANNELS BACK TO BACK THE ENDS OF THE CHANNELS SHOULD BE CLAMPED WITH THE SPACER, PC 9, AND BOLTS SHOWN ON FIGURE 14. SH. 1
7. HOLES SHOULD NOT BE DRILLED THROUGH THE FLANGES OF THE SUPPORTING CHANNELS FOR THE PURPOSE OF BOLTING EQUIPMENT. EQUIPMENT SHOULD BE BOLTED TO THE SUPPORTING CHANNELS BY MEANS OF THE T CLAMP SHOWN ON FIGURE 14. SH. 1
8. THE SPACING OF THE SUPPORTING CHANNELS ON THE SHIPBUILDING CHANNELS SHOULD BE GOVERNED, WHEN PRACTICABLE, BY THE POSITION OF THE CENTER OF GRAVITY TO OBTAIN UNIFORM DISTRIBUTION OF LOAD.
9. IF THE EQUIPMENT MOUNTING FEET ARE NOT SUBSTANTIALLY WIDER THAN DIMENSION 'C', A STEEL PAD SHOULD BE USED BETWEEN THE FEET AND SUPPORTING CHANNELS AT EACH MOUNTING BOLT AND CLAMP.
10. FOR EQUIPMENT REQUIRING TWO OR MORE CAR BUILDING SUPPORTING CHANNELS, ALL OR PART OF THE NUMBER OF CAR BUILDING CHANNELS AS INDICATED IN THE TABLE MAY BE REPLACED WITH STANDARD CHANNELS TO UTILIZE A BACK TO BACK CHANNEL ARRANGEMENT-NOTE 7. IN THE EVENT THAT THE REQUIRED NUMBER OF SUPPORTING CHANNELS DOES NOT LEND ITSELF TO THIS METHOD, THE AUXILIARY CHANNEL ARRANGEMENT OF CASE 3 SHOULD BE USED.
11. FOR EQUIPMENT HAVING AN IRREGULAR OR CIRCULAR MOUNTING BOLT HOLE PATTERN (UTILIZE 'T' CLAMPS OF SUFFICIENT SIZE AND NUMBER TO PROVIDE TOTAL BOLTING STRENGTH AT LEAST 50 PERCENT GREATER THAN PROVIDED BY EQUIPMENT BOLTS.)
12. FOR ADDITIONAL DETAILS, SEE BUSHIPS DRAWING N0807-655947.

NUMBER OF SUPPORTING 4" CAR BUILDING CHANNELS REQUIRED FOR A GIVEN EQUIPMENT WEIGHT & SIZE

WEIGHT OF EQUIPMENT (SEE NOTE 4)	CENTER DISTANCE BETWEEN BOLT HOLES DIMENSION 'A' (INCHES)																	
	10	12	14	16	18	20	22	24	26	28	30	32	34	36	38	40	42	44
500	2	2	2	2	2	2	2	2	2	2	2	2	2	2	2	2	2	2
600	2	2	2	2	2	2	2	2	2	2	2	2	2	2	2	2	2	2
700	3	3	3	2	2	2	2	2	2	2	2	2	2	2	2	2	2	2
800	3	3	3	3	2	2	2	2	2	2	2	2	2	2	2	2	2	2
900	3	3	3	3	3	2	2	2	2	2	2	2	2	2	2	2	2	2
1000	4	4	3	3	3	3	2	2	2	2	2	2	2	2	2	2	2	2
1100	4	4	4	3	3	3	3	2	2	2	2	2	2	2	2	2	2	2
1200	4	4	4	4	3	3	3	3	2	2	2	2	2	2	2	2	2	2
1300	5	4	4	4	4	3	3	3	2	2	2	2	2	2	2	2	2	2
1400	5	5	4	4	4	4	4	3	3	3	2	2	2	2	2	2	2	2
1500	5	5	5	5	4	4	4	3	3	3	3	2	2	2	2	2	2	2
1600	6	5	5	5	4	4	4	4	3	3	3	2	2	2	2	2	2	2
1700	6	6	5	5	5	4	4	4	4	3	3	3	3	3	3	3	3	3
1800	6	6	6	5	5	5	4	4	4	4	3	3	3	3	3	3	3	3
1900	7	6	6	6	5	5	4	4	4	4	3	3	3	3	3	3	3	3
2000	7	7	6	6	6	5	5	4	4	4	4	3	3	3	3	3	3	3
2100	7	7	7	6	6	6	5	5	4	4	4	3	3	3	3	3	3	3
2200	8	7	7	7	6	6	6	5	5	4	4	3	3	3	3	3	3	3
2300	8	8	7	7	7	6	6	6	5	5	4	4	3	3	3	3	3	3
2400	8	8	8	7	7	6	6	6	5	5	4	4	3	3	3	3	3	3
2500	8	8	8	7	7	7	6	6	5	5	4	4	4	4	4	4	4	4
2600			8	8	7	7	7	6	6	5	5	4	4	4	4	4	4	4
2700				8	8	7	7	6	6	5	5	4	4	4	4	4	4	4
2800					8	8	7	7	6	6	5	5	4	4	4	4	4	4
2900						8	8	7	7	6	6	5	5	4	4	4	4	4
3000							8	8	7	7	6	6	5	5	4	4	4	4
3100								8	8	7	7	6	6	5	5	4	4	4
3200									8	8	7	7	6	6	5	5	4	4
3300										8	8	7	7	6	6	5	5	5
3400											8	8	7	7	6	6	5	5
3500												8	8	7	7	6	6	5
3600													8	8	7	7	6	6
3700														8	8	7	7	6
3800															9	8	7	7
3900																9	8	7
4000																	9	8
4100																		9
4200																		
4300																		
4400																		
4500																		
4600																		
4700																		
4800																		
4900																		
5000																		
5100																		
5200																		
5300																		
5400																		
5500																		
5600																		
5700																		
5800																		
5900																		
6000																		

SH 132031651

FIGURE 13. Standard mounting platform for testing equipment on mediumweight shock testing machine. (Sheet 3 of 3)

MIL-S-901D(NAVY)

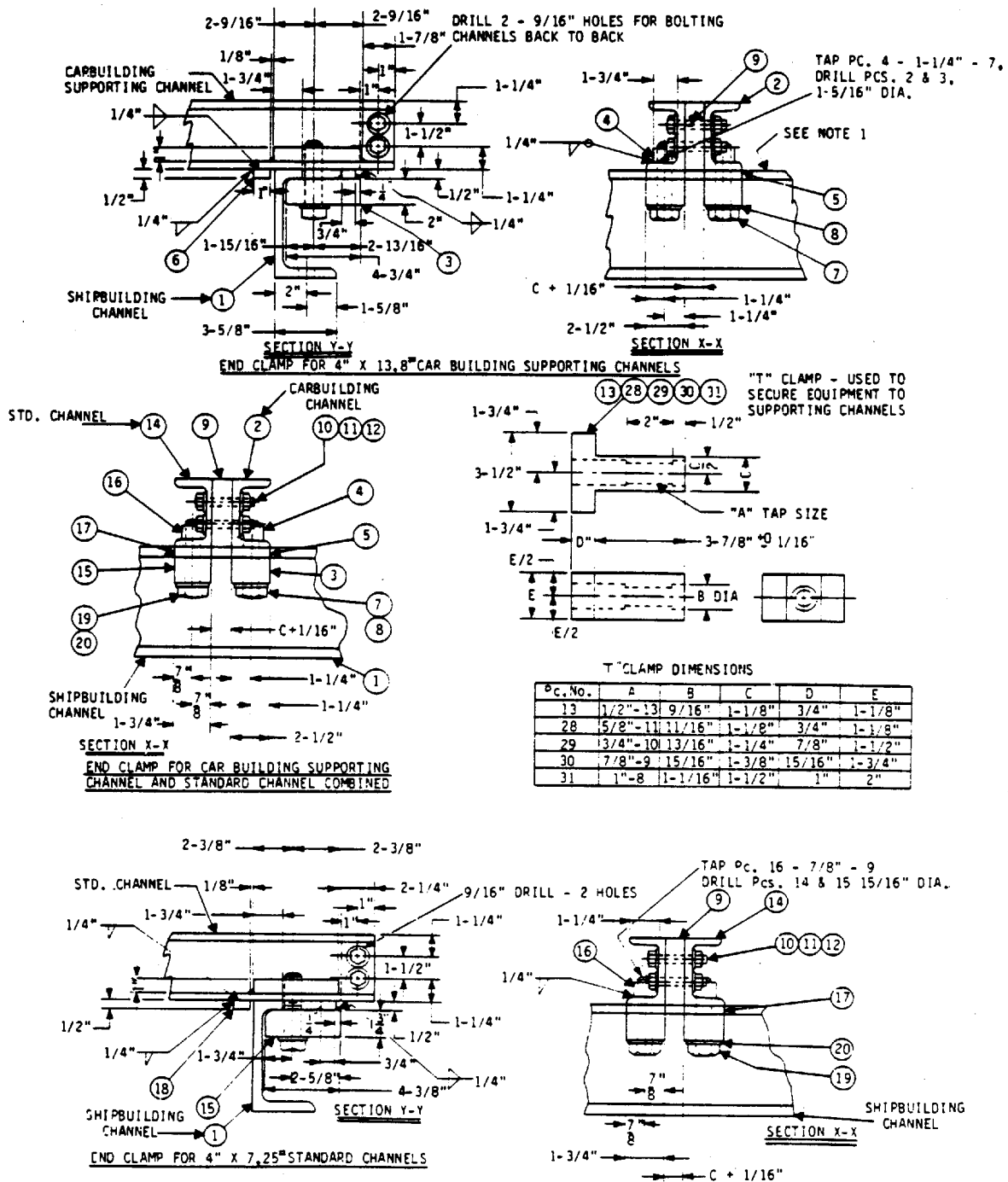

SH 132031652

FIGURE 14. Section details of standard mounting platform for testing equipment on mediumweight shock testing machine. (Sheet 1 of 3)

MIL-S-901D(NAVY)

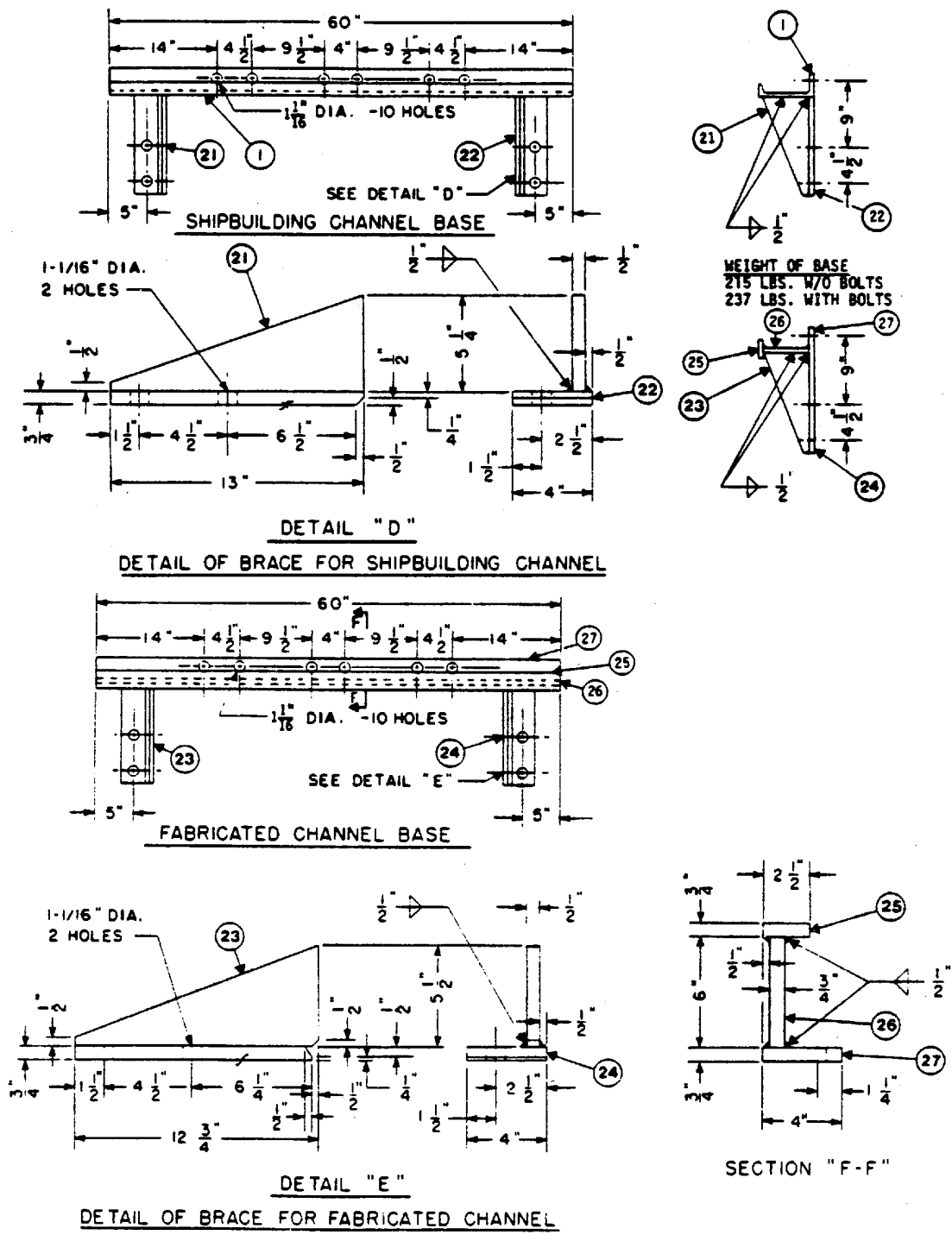

SH 132031652

FIGURE 14. Section details of standard mounting platform for testing equipment on mediumweight shock testing machine. (Sheet 2 of 3)

## MIL-S-901D(NAVY)

PC. NO.	ITEM	SIZE (INCHES)	NO. REQ.
1	SHIPBUILDING CHANNEL	7 X 22.7"	2
2	CARBUILDING CHANNEL	4 X 13.8"	A/R
3	CLAMP	2" X 2 1/2" X 4 3/4"	A/R
4	BLOCK	1" X 1 3/4" X 5 1/8"	A/R
5	PAD	1/2" X 3/4" X 2 1/2"	A/R
6	PAD	1/2" X 1" X 2"	A/R
7	HEXAGON HEAD BOLT	1 1/4"-7 X 4 1/4" LG.	A/R
8	WASHER	1 3/8" I.D. X 2 5/16" O.D.	A/R
9	SPACER	2" X 4" X A/R	A/R
10	HEXAGON HEAD BOLT*	1/2"-13 X A/R	A/R
11	WASHER	9/16" I.D. X 1" O.D.	A/R
12	HEXAGON HEAD NUT	1/2"-13	A/R
13	CLAMP	See Fig 14 Sht 1	A/R
14	STANDARD CHANNEL	4" X 7.25"	A/R
15	CLAMP	1 3/4" X 1 3/4" X 4 3/8"	A/R
16	BLOCK	1" X 1 1/4" X 4 3/4"	A/R
17	PAD	1/2" X 3/4" X 1 3/4"	A/R
18	PAD	1/2" X 1" X 1 1/4"	A/R
19	HEXAGON HEAD BOLT*	7/8"-9 X 3 5/8" LG.	A/R
20	WASHER	15/16" I.D. X 1 9/16" O.D.	A/R
21	GUSSET	1/2" X 5 1/4" X 13"	A/R
22	PLATE	3/4" X 4" X 13"	A/R
23	GUSSET	1/2" X 5 1/2" X 12 3/4"	A/R
24	PLATE	7/8" X 4" X 12 1/4"	A/R
25	PLATE	7/8" X 2 1/2" X 60"	A/R
26	PLATE	3/4" X 6" X 60"	A/R
27	PLATE	7/8" X 4" X 60"	A/R
28	CLAMP	See Fig 14 Sht 1	A/R
29	CLAMP	See Fig 14 Sht 1	A/R
30	CLAMP	See Fig 14 Sht 1	A/R
31	CLAMP	See Fig 14 Sht 1	A/R

MATERIAL SHALL BE STEEL  
\*Heat treated steel

## NOTES:

1. TOP FLANGE OF PC. NO. 1 SHALL BE BURNED OR CUT OFF TO A WIDTH OF 1 3/4"
2. PC. NOS. 3 AND 4 SHALL BE SHAPED TO FIT INNER SURFACES OF PC. NOS. 1 AND 2 RESPECTIVELY. (SEE NOTE 5)
3. PC. NOS. 15 AND 16 SHALL BE SHAPED TO FIT INNER SURFACES OF PC. NOS. 1 AND 14 RESPECTIVELY. (SEE NOTE 5)
4. USE OF EITHER PC. NO. 1 OR THE FABRICATED CHANNEL, SECTION "F-F" OF FIG. 9-2 IS OPTIONAL DEPENDENT UPON AVAILABILITY OF MATERIAL OR EASE OF FABRICATION.
5. IF THE FABRICATED CHANNEL, SECTION "F-F" IS USED, PC. NOS. 3 AND 15 SHOULD BE SHAPED TO FIT THE INNER SURFACE OF THE FABRICATED CHANNEL, SECTION "F-F", RATHER THAN PC. NO. 1. PC. NOS. 6 AND 18 SHALL EACH BE SHIFTED INWARD 3/4".
6. USE OF BACK TO BACK SUPPORTING CHANNELS WHICH ARE PERMANENTLY WELDED TOGETHER AT THE ENDS RATHER THAN BOLTED TOGETHER, IS OPTIONAL.

SH 132031652 FOR ADDITIONAL DETAILS, SEE BUSHIPS DWG N0807-655947

FIGURE 14. Section details of standard mounting platform for testing equipment on mediumweight shock testing machine. (Sheet 3 of 3)

MIL-S-901D(NAVY)

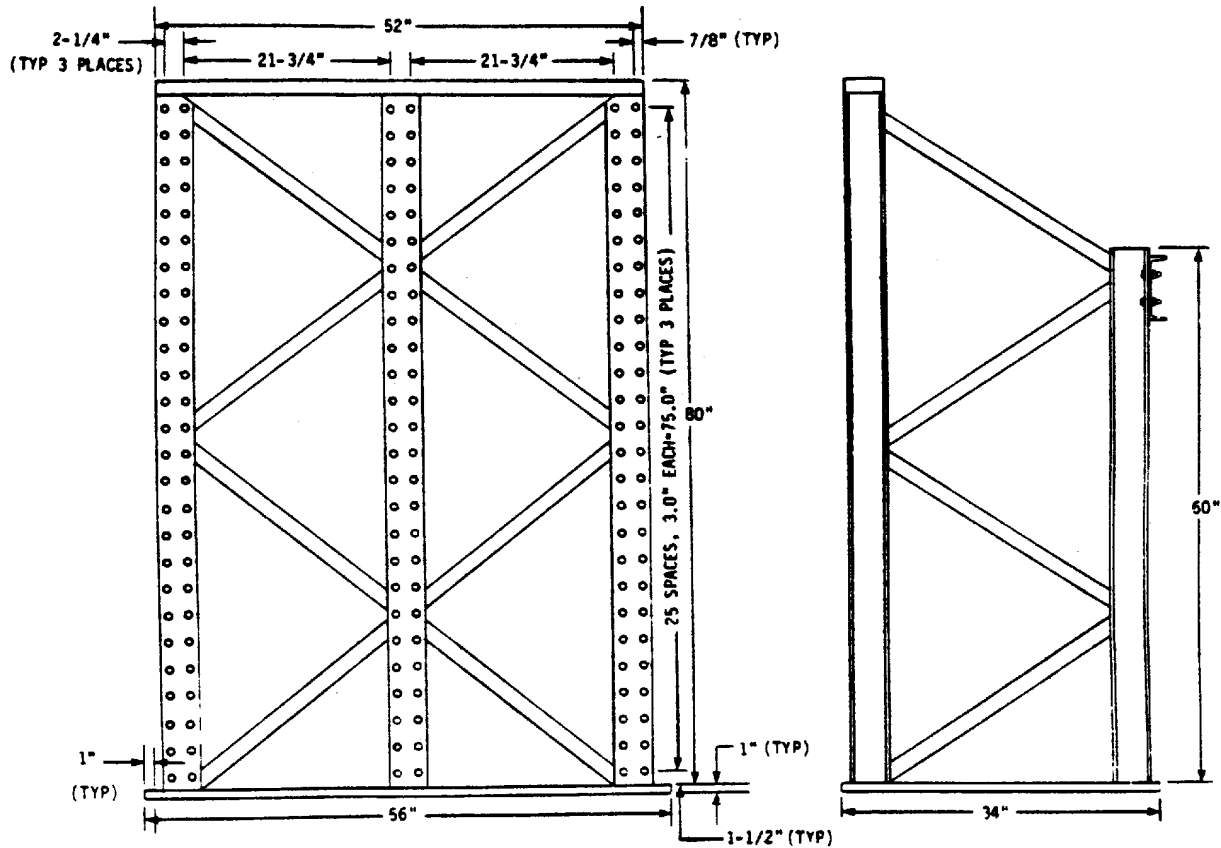

PC. NO.	ITEM	SIZE	NO. REQ'D
1	H-BEAM	4.0x4.0x.25 WEB, 78.0 LONG	3
2	H-BEAM	4.0x4.0x.25 WEB, 60.0 LONG	3
3	CHANNEL	4.0x1-5/8x.25 WEB, 52.0 LONG	1
4	CHANNEL	4.0x1-5/8x.25 WEB, 29-3/8 LONG	2
5	CHANNEL	4.0x1-5/8x.25 WEB, 30-3/4 LONG	12
6	CHANNEL	4.0x1-5/8x.25 WEB, 30-1/4 LONG	12
7	PLATE	1.0x8.0 34.0 LONG	3
8	BAR	1.0x2.0 16.0 LONG	4
9	STIFFENER	1.0 DIA. 3-1/2 LONG	10
10	PAD	1 3/4x2.0x4.0	2
11	CHANNEL	7.0x2-1/8x.25 WEB, 52 LONG	1

MATERIAL: STEEL  
 WEIGHT: 1088 lbs.

FOR ADDITIONAL DETAILS, SEE BUSHIPS DWG N0807-655947.

SH 132031653

FIGURE 15. Standard mounting fixture for testing bulkhead mounted equipment on mediumweight shock testing machine.



## MIL-S-901D(NAVY)

PIECE NO.	SIZE	MATERIAL	NO. REQUIRED
1	1 X 4 X 70	HRS 1010	2
2	1/2 X 9-1/2 X 12-1/2		2
3	1/2 X 8 X 13-1/2		2
4	1/2 X 8 X 18-1/2		2
5	1/2 X 8 X 24-1/2		2
6	1/2 X 8 X 29		2
7	1/2 X 14 X 36		2
8	1 X 26 X 60		2
9	1/2 X 22 X 36		2
10	1/2 X 7 X 6-1/2		2
11	3/4 X 60 X 41	HRS 1010	2
12	1/4 X 60 X 60	61 ST	1
13	1/2 X 5 X 27	HRS 1010	2

MATERIAL: STEEL  
WEIGHT OF FIXTURE (BOTH PIECES) 1400 POUNDS

## NOTES:

- THIS FIXTURE, WHEN USED, REPLACES THE SHIPBUILDING OR FABRICATED CHANNELS SHOWN ON FIGURES 13 AND 14. EQUIPMENT AND SUPPORTING CHANNELS ARE MOUNTED TO THIS FIXTURE AS SHOWN ON FIGURE 13.
- THIS FIXTURE MAY BE USED TO TEST BULKHEAD MOUNTED EQUIPMENT AT 30 DEGREE INCLINATION BY ADDING BULKHEAD FIXTURE SHOWN ON FIGURE 15. SEE FIGURE 18 FOR ALTERNATE 30 DEGREE MOUNTING PLATFORM FOR BULKHEAD SUPPORTING EQUIPMENT.
- FULLY ANNEAL ASSEMBLY AFTER WELDING.
- FINISH MACHINE AFTER ANNEALING.
- PIECE NO. 12 IS NOT A PART OF THE FIXTURE. IT IS A TEMPLATE HAVING A HOLE PATTERN IDENTICAL TO THE HI SHOCK TEST MACHINE PLATFORM. LOCATE ALL 1-1/16 INCH DIAMETER HOLES FROM SHOCK MACHINE PLATFORM.
- ALL WELDS TO BE 1/2 INCH COMPLETELY AROUND EACH EDGE.
- TWO-INCH DIAMETER HOLE SHALL BE TORCH CUT AFTER WELDING. THE HOLE SHALL BE LOCATED NEAR THE CENTER OF GRAVITY.
- ALL EDGES AND CORNERS SHALL BE BROKEN SUITABLE FOR HANDLING.
- PARALLELISM SHALL BE MAINTAINED AT SURFACES "B" AND EDGES "A" WITHIN 1/32 INCH.
- FOR ADDITIONAL DETAILS, SEE BUSHIPS DWG N0807-655947.

SH 132031654

FIGURE 16. 30 degree mounting fixture for testing base mounted equipment on mediumweight shock testing machine. (Sheet 2 of 2)

MIL-S-901D(NAVY)

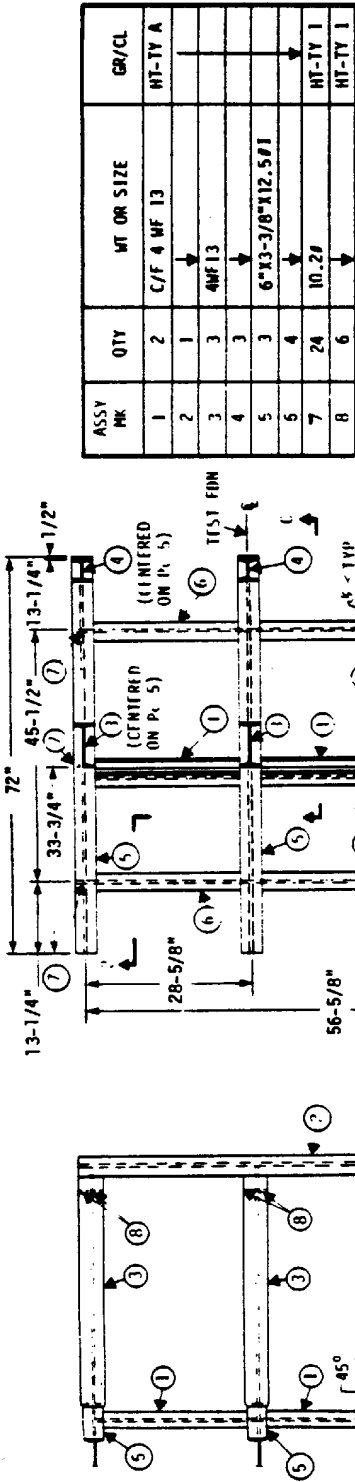

ASSY PK	QTY	WT OR SIZE	GR/CL
1	2	C/F 4 WF 13	HT-TV A
2	1	↓	
3	3	4WF 13	
4	3	↓	
5	3	6"X3-3/8"X12.5#1	
6	4	↓	
7	24	10.2#	HT-TV 1
8	6	↓	HT-TV 1

- NOTES:
1. THIS FIXTURE MAY BE USED IN LIEU OF FIGURE 16. IT PROVIDES IMPROVED SUPPORT FOR MARRON BASE EQUIPMENTS BY THE REORIENTED SUPPORTING CHANNELS AND DUE TO ITS REDUCED WEIGHT, PERMITS TESTING HEAVIER EQUIPMENT WITHOUT EXCEEDING THE MAXIMUM WEIGHT LIMIT OF 7400 POUNDS
  2. WEIGHT OF FIXTURE 1250 POUNDS.
  3. FOR ADDITIONAL DETAILS, SEE BUSHIPS DMG NO807-655947.

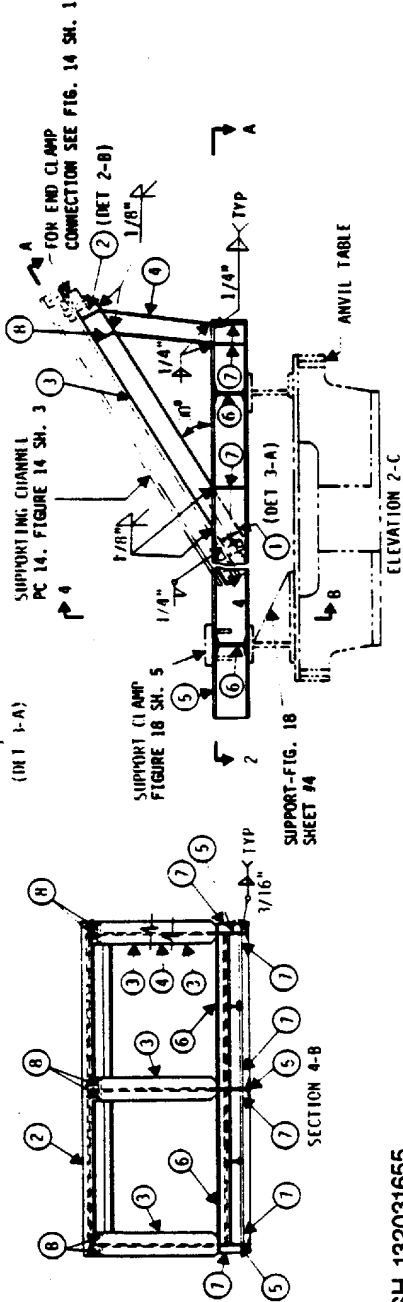

FIGURE 17. 30 degree mounting fixture for testing base mounted equipment on mediumweight shock testing machine.

SH 132031655



## MIL-S-901D(NAVY)

## LIST OF MATERIAL

PIECE NO.	ITEM	SIZE INCHES	LENGTH INCHES	NO. REQUIRED
1	H-BEAM	6.0 X 3-1/2 X 0.25 WEB	72	3
2	H-BEAM	6.0 X 3-1/2 X 0.25 WEB	20-3/4	8
3	H-BEAM	4.0 X 2-5/8 X 0.25 WEB	74	2
4	H-BEAM	4.0 X 2-5/8 X 0.25 WEB	82	2
5	H-BEAM	4.0 X 2-5/8 X 0.25 WEB	75	2
6	H-BEAM	4.0 X 2-5/8 X 0.25 WEB	52	2
7	H-BEAM	4.0 X 2-5/8 X 0.25 WEB	45	1
8	H-BEAM	4.0 X 2-5/8 X 0.25 WEB	50	2
9	H-BEAM	4.0 X 2-5/8 X 0.25 WEB	17-1/2	1
10	H-BEAM	4.0 X 2-5/8 X 0.25 WEB	16-3/4	2
11	T-BEAM	3.0 X 3.0 X 0.25 WEB	59	1
12	T-BEAM	3.0 X 3.0 X 0.25 WEB	24-3/4	1
13	T-BEAM	3.0 X 3.0 X 0.25 WEB	20-3/4	2
14	CHANNEL	4.0 X 1-3/4 X 0.25 WEB	41	16
15	PLATE	5/8 X 42	42	1
16	STIFFENER	3/8 X 8.0	15	2
17	STIFFENER	3/8 X 5-1/2	15	1
18	STIFFENER	3/8 X 5-1/4	5-1/4	4
19	STIFFENER	3/8 X 1-5/8	5-1/2	24
20	PAD	3/8 X 3.0	14-3/4	2
21	PAD	3/8 X 3.0	10-3/4	2
22	PAD	3/8 X 3.0	8-1/4	2
23	PAD	3/8 X 3.0	6	2
24	PAD	3/8 X 1-1/2	1-1/2	72

WEIGHT OF FIXTURE: 1733 POUNDS  
MATERIAL: STEEL

SH 132031656

FIGURE 18. 30 degree mounting fixture for testing bulkhead mounted equipment on mediumweight shock testing machine. (Sheet 2 of 5)

## MIL-S-901D(NAVY)

## NOTES:

1. UNLESS OTHERWISE SPECIFIED HEREIN OR IN THE INDIVIDUAL EQUIPMENT SPECIFICATION, SURFACE ROUGHNESS, AS ROLLED OR DRAWN, PUNCH CUT OR MACHINED SHALL HAVE A 250 FINISH AND SHALL BE IN ACCORDANCE WITH ANSI B46.1.
2. THREADS SHALL BE IN ACCORDANCE WITH FED-STD-H28 AND ANSI Y14.6.
3. UNLESS OTHERWISE SPECIFIED HEREIN OR IN THE INDIVIDUAL EQUIPMENT SPECIFICATION, ALL FILLET WELDS SHALL BE 1/4-INCH.
4. MACHINED SURFACES SHALL NOT BE PAINTED.
5. FABRICATION PROCEDURES AND INSPECTION STANDARDS FOR WELDING SHALL BE IN ACCORDANCE WITH CLASS 1 OF MIL-W-21157. WELD SHALL BE THE MANUAL SHIELDED ARC PROCESS USING WELDING ELECTRODE TYPE 7018 OF MIL-E-22200/1.
6. STRESS RELIEF SHALL BE AT  $1175^{\circ} \pm 25^{\circ}\text{F}$  FOR A MINIMUM OF 3 HOURS, THEN THE FURNACE SHALL BE COOLED.
7. WELDING SYMBOLS SHALL BE AS SPECIFIED IN AWS A2.4.
8. WELDING TERMS AND DIFINITIONS SHALL BE IN ACCORDANCE WITH AWS A3.0.
9. WELDED-JOINT DESIGNS SHALL BE AS SPECIFIED IN MIL-STD-22.
10. DIMENSIONS AND TOLERANCES SHALL BE AS SPECIFIED IN ANSI Y14.5.
11. THIS FIXTURE IS ATTACHED TO THE ANVIL PLATE OF THE MWSM BY MEANS OF SUPPORTS AND CLAMPS SHOWN ON SHEETS 4 AND 5.
12. FOR ADDITIONAL DETAILS, SEE BUSHIPS DWG N0807-655947.

SH 132031656

FIGURE 18. 30 degree mounting fixture for testing bulkhead mounted equipment on mediumweight shock testing machine. (Sheet 3 of 5)

MIL-S-901D(NAVY)

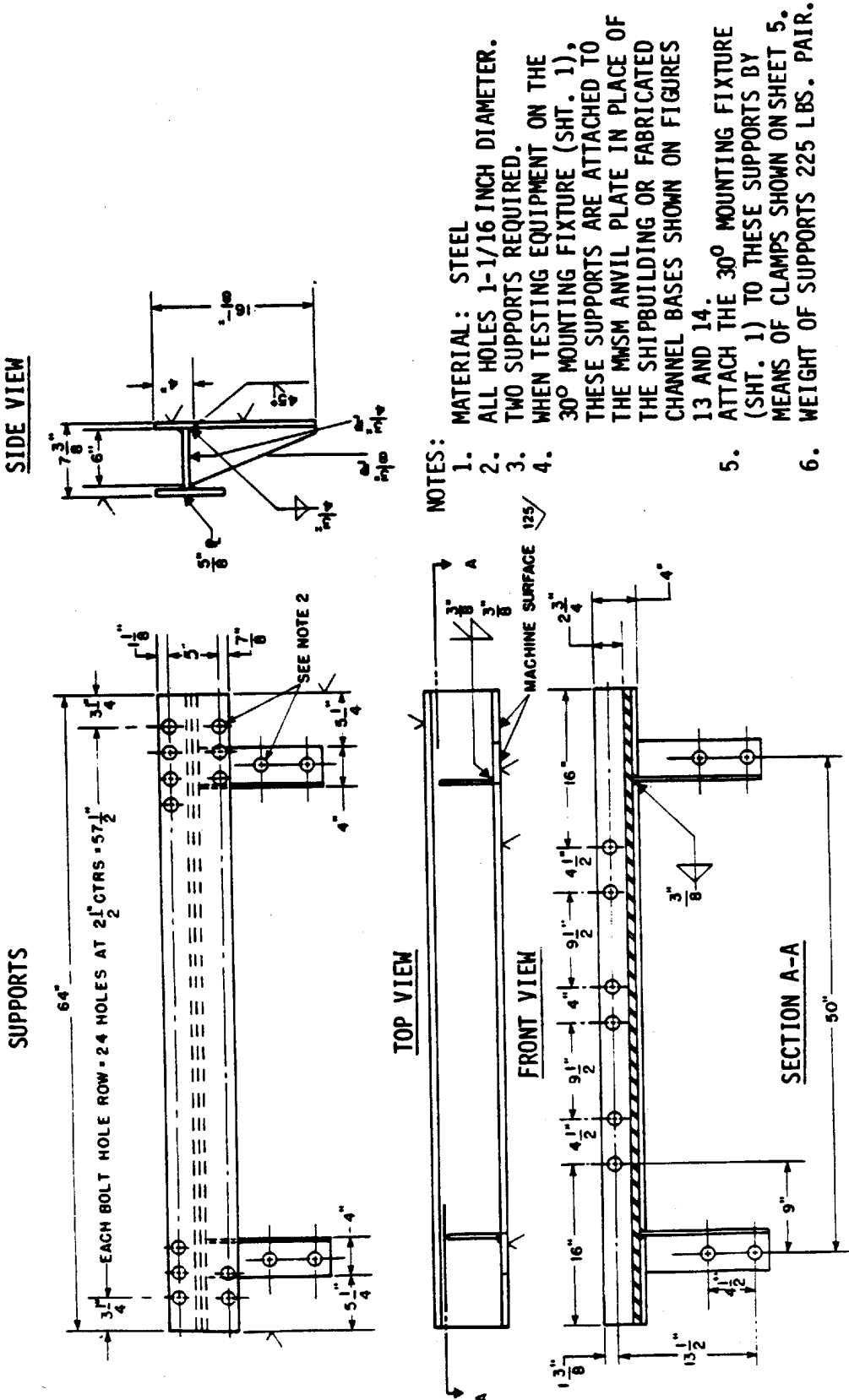

SH 132031656

FIGURE 18. 30 degree mounting fixture for testing bulkhead mounted equipment on mediumweight shock testing machine. (Sheet 4 of 5)

MIL-S-901D(NAVY)

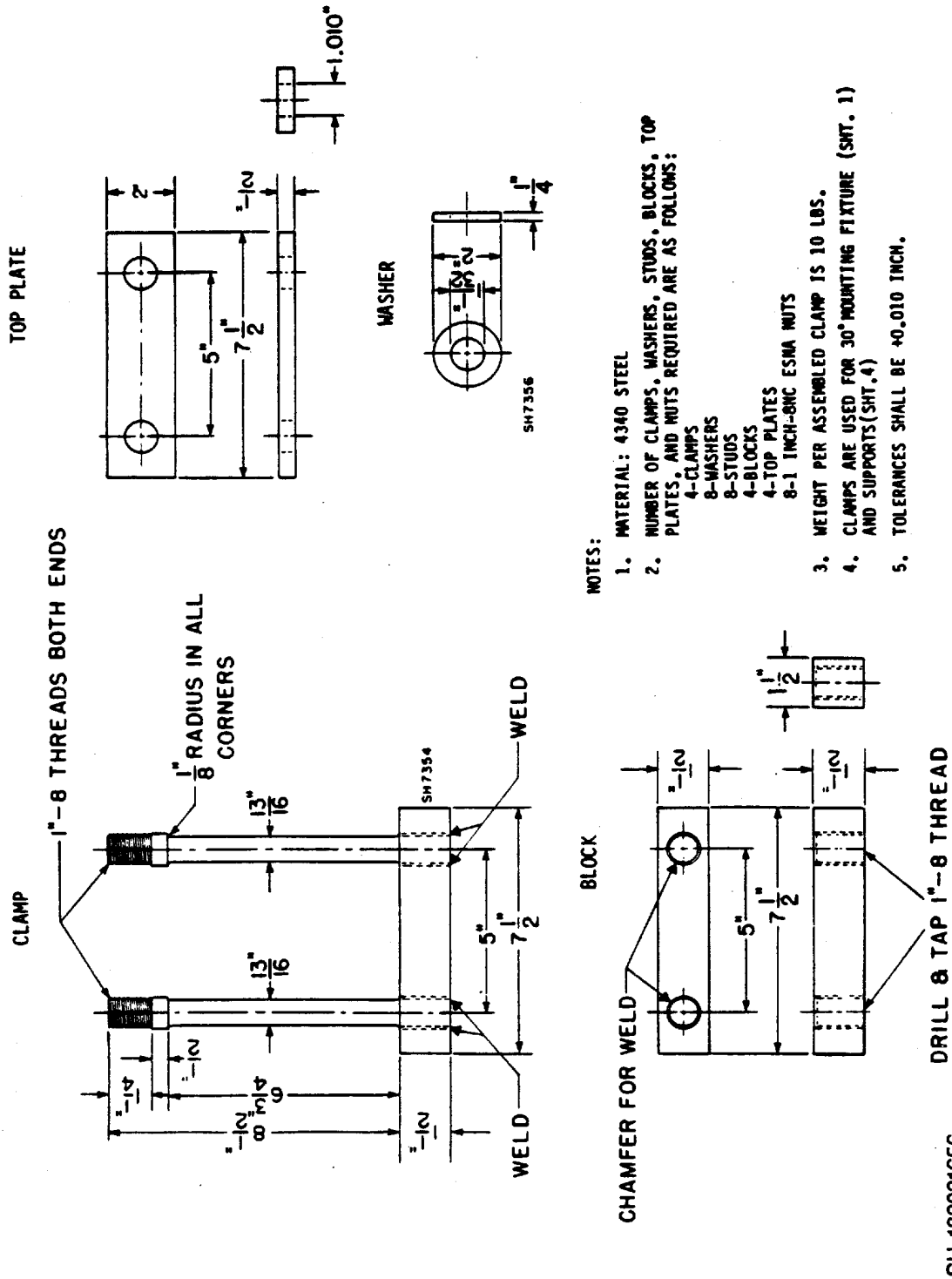

FIGURE 18. 30 degree mounting fixture for testing bulkhead mounted equipment on mediumweight shock testing machine. (Sheet 5 of 5)

## MIL-S-901D(NAVY)

1. The item identified below has met the requirements of Military Specification MIL-S-901, based upon:
  - Shock testing of the item identified below
  - Previous shock testing of an item similar to the item identified below (shock test extension)
  - Previous shock testing of an item identical to the item identified below (shock test extension)
2. Item (Nomenclature) \_\_\_\_\_
3. Item (Description) \_\_\_\_\_
4. Manufacturer \_\_\_\_\_
5. Model \_\_\_\_\_ 6. Size/Capacity \_\_\_\_\_
7. Drawing Number \_\_\_\_\_ 8. Revision and Date \_\_\_\_\_
9. Military Specification \_\_\_\_\_
10. Ship \_\_\_\_\_ 11. Service \_\_\_\_\_
12. Contract No. \_\_\_\_\_
13. Shock Test Facility \_\_\_\_\_
14. Report No. \_\_\_\_\_
15. Previous Shock test approval reference (if this form conveys shock test extension approval) \_\_\_\_\_
16. Test Category     Lightweight     Mediumweight     Heavyweight
17. Shock Grade         A                             B
18. Equipment Class     I                             II                     III
19. Shock Test Type     A                             B                     C
20. Mounting Location     Deck         Hull             Shell         Wetted-Surface
21. Shipboard mounting plane represented during shock test:
  - Base                     Front or face                     Back
  - Top                     Combination                     Other \_\_\_\_\_
22. Mounting orientation of item relative to ship's fore-and-aft axis (for mediumweight and heavyweight test items only): \_\_\_\_\_
23. Approval Limitations: \_\_\_\_\_
24. Approved. \_\_\_\_\_

Authorized Signature                      Approval activity                      Date

FIGURE 19. Shock test acceptance information