

MILITARY SPECIFICATION

TRANSIT CASES, COMBINATION CASES AND SPARE PARTS CASES
FOR GROUND ELECTRONIC EQUIPMENT (USAF)
(REQUIREMENTS FOR)

1. SCOPE

1.1 This specification covers the requirements for two types of transit cases designated Transit Cases, Combination Cases and Spare Parts Cases, Type I or Type II hereinafter referred to as the "type number" or "transit case" when referred to collectively. These cases are to serve as shipping containers with no further overpacking required.

1.2 Types.- The cases shall be of the following types:

- a. Type I - Rectangular parallelepipeds
- b. Type II - Cylindrical

1.3 Classes.- The cases shall be of the following classes:

- a. Class 1 - Submersible (See 6.3)
- b. Class 2 - Splashproof (See 6.3)

2. APPLICABLE DOCUMENTS

2.1 The following documents of the issue in effect on date of invitation for bids, or request for proposals, form a part of this specification to the extent specified herein.

SPECIFICATIONS

Military

MIL-I-631

MIL-E-4158

Insulation, Electrical, Synthetic-
Resin Composition Non Rigid
Electronic Equipment Ground:
General Requirements For

FSC MISC.

MIL-N-7513

Nomenclature Assignment and Name-plate Approval, Contractor's Method For Obtaining

MIL-F-14072

Finishes For Ground Signal Equipment

STANDARDS

Federal

FED-STD-595

Colors

Military

MIL-STD-105

Sampling Procedures and Tables For Inspection by Attributes

MIL-STD-129

Marking For Shipment and Storage

MIL-STD-417

Rubber Compositions, Vulcanized General Purpose, Solid, Symbols And Tests

MIL-STD-454

Standard General Requirements For Electronic Equipment

MIL-STD-810

Environmental Test Methods For Aerospace and Ground Equipment

MIL-STD-831

Test Reports, Preparation Of

(Copies of documents required by contractors in connection with specific procurement functions should be obtained from the procuring activity or as directed by the contracting officer.)

3. REQUIREMENTS

3.1 Preproduction.- This specification makes provisions for preproduction testing.

3.2 General specification.- The requirements of MIL-E-4158 apply as requirements of this specification with the exceptions and additions called out herein. When the two specifications conflict, this specification shall govern.

3.2.1 Exceptions to the requirements of MIL-E-4158.

3.2.1.1 Service conditions.- The transit case shall be designed and constructed to operate under any combination of the service conditions specified in the general specification with exceptions and additions as follows:

3.2.1.1.1 Mechanical.- The transit case shall be designed and constructed to meet the following mechanical conditions, as detailed in section 4 of this specification.

- a. Air relief valve test
- b. Static load test
- c. Impact test
- d. Bounce test
- e. Handle pull test
- f. Drop test

3.2.1.1.2 Environmental.- The transit case shall be designed and constructed to meet the following environmental conditions, as detailed in Section 4 of this specification:

- a. Humidity test
- b. Salt spray test
- c. Submersion test
- d. Splash test

3.2.1.2 Pad and gasket materials.- Pad materials shall be in accordance with MIL-STD-417. Gasket material shall conform to SC41ZA,B,F2K2 thereof with the grade chosen in accordance with requirements of the application.

3.2.1.3 Lightweight material.- Lightweight high strength materials shall be used.

3.2.1.4 Threaded devices and hardware.- Threaded devices and hardware shall be in accordance with MIL-STD-454, requirement 12, Application of Fastener Hardware for Electronic Equipment.

3.2.1.5 Dissimilar metals.- The selection and protection of dissimilar metal combinations shall be in accordance with MIL-STD-454, requirement 16.

3.2.1.6 Nomenclature.- Nomenclature shall be obtained in accordance with the requirements of MIL-N-7513. The parentheses appearing in the nomenclature may be dropped, or replaced by a letter to designate the particular design.

3.3 Design and Construction

3.3.1 General.- The transit case shall provide protection for contained equipment, specified by the procuring activity, against shock, vibration, and deterioration from all environmental conditions that might be encountered during storage, shipment, and unlimited use. The detailed mechanical design of the case shall be accomplished subject to the requirements of this specification. Design of the particular case shall be approved by the procuring activity. (See 6.2.c)

3.3.1.1 The transit case shall consist of two parts (cover and body) and shall readily receive the equipment in its supporting pads without binding. Its design shall permit the cover being placed in position and clamped in order to provide a tight fitting, protective case.

3.3.2 Case materials.- The transit case shall be constructed of metal, plastic, or sandwich material or a metal plastic combination strong enough to meet the requirements of this specification. The case shall not be constructed of steel.

3.3.3 The transit cases shall be so designed that they shall geometrically lend themselves to stacking without harm to case or contained equipment.

3.3.4 The transit cases shall be of the minimum volume and weight compatible with the requirements of this specification.

3.3.5 All external hardware employed on the transit cases shall be recessed or protected by bosses or corrugations. These bosses and corrugations shall in no way be a detriment to the transit cases.

3.3.6 Covers.- Covers shall be made detachable from the transit case. They shall be designed so that thrusts on the corners, such as encountered in service and in the drop test, shall not be conveyed to the catches.

3.3.7 Reinforced corners.- Rectangular transit cases shall be provided with reinforced corners.

3.3.8 Shock-mounts.- Provision shall be made for shockproofing the contained equipment. There shall be two acceptable methods of shock mounting as follows. The best adaptable method shall be used.

a. A shock-mounted frame of a lightweight metal of welded, riveted, or bolted construction shall be secured to the transit case by means of shock-mounts or pads which shall be clipped and bonded, welded, bolted, or riveted to the transit case.

b. Shock pads shall be fastened to the inside of the transit case. The pads shall be held in place by metal clips and an adhesive, and shall be so placed as to prevent movement of the enclosed equipment.

NOTE: This requirement shall not apply when rugged items such as anchors, cables, tools, et cetera, are to be contained within the spare parts case.

3.3.9 Anti-roll provisions.- The cylindrical Type II case shall have provisions for the prevention of rolling. These provisions shall be compact and well designed and shall not be a detriment to the case nor a hazard to the operating personnel.

3.3.10 Air relief valve.- Each transit case shall be equipped with a two-way air relief valve (automatic) in order to comply with the pressure difference incurred during high altitude air transport conditions and other pressure differences. The air relief valve shall actuate at a pressure differential of 2 to 3 pounds.

3.3.11 Construction.- Transit cases shall be constructed in parallelepiped or cylindrical form. Cylindrical Type II cases may be used for equipment conforming to the following limitations:

a. Weight of the transit case with contained equipment shall not exceed 30 pounds.

b. Dimensional relationship of noncylindrical contained equipment shall conform to the following:

$\frac{L}{W + H}$ shall be equal to or greater than 5

c. Dimensional relationship of cylindrical contained equipment shall conform to the following:

$\frac{L}{D}$ shall be equal to or greater than 5

Legend: L is over-all length of component in inches
W is over-all width of component in inches
H is over-all depth of component in inches
D is largest diameter of component in inches

3.3.12 Cover fastening.- The cover for the transit case shall be secured to the body by means of hand-operated, spring-loaded compression catches or pull-down type tension latches. (NOTE: The words "catches, latches, clamps and clasps" are considered synonymous for the purposes of this specification.) The main portion of the catch shall be on the body and the smaller portion on the cover of the transit case. The catch design shall conform to the following:

a. The catch spring shall be protected from being damaged by contact with other objects.

b. Catches utilizing or depending on the engagement of threads as in bolts and nuts shall not be used.

c. Locking and unlocking of catches shall not cause injury to personnel operating catches.

d. Catches shall not be damaged by temperature extremes, mud, ice, water, or snow, and shall have the capability of being unlocked when iced, or enclosed with foreign matter.

3.3.13 Carrying handles

3.3.13.1 Handles for Type I rectangular cases.- Rectangular Type I cases shall be provided with handles having a free-moving, grip portion of at least 3 1/2 inches with a minimum diameter of 1/2 inch in accordance with MIL-I-631. They shall be attached to the Type I case in such a manner that shall provide clearance sufficient to pass a block 1 7/8 inches by 4-1/2 inches in cross section and having edges rounded to a 15/16 inch radius. The following features shall also be incorporated:

a. Handles shall stop open at 90 degrees and shall be returned to the sides by a spring-loaded or retaining mechanism when not in use.

b. Handles shall have slight protrusions to keep most of the handle surface a small distance away from the case side to facilitate opening handles and to reduce susceptibility to ice loading.

3.3.13.2 Handle for cylindrical Type II cases.- Each handle shall be a cotton or nylon web strap, large enough for the passage of a normal hand covered with an Arctic glove. The strap handle shall be secured to the body of the Type II case by swivel rings.

3.3.13.3 Number and location of handles

3.3.13.3.1 Rectangular Type I cases.- The number and location of handles for each rectangular Type I case shall be determined as follows:

- a. If the ratio of $\frac{L}{W + d}$ is equal to or less than 2,

Table 1 shall be used

Table 1

<u>Weight of Case and Equipment</u>	<u>No of Handles</u>	<u>Location</u>
Up to 20 pounds	2	1 on cover 1 on side
20 to 100 pounds	2	on opposite sides
100 to 200 pounds	4	2 on one side 2 on opposite side

- b. If the ratio of $\frac{L}{W + d}$ is greater than 2, then three or

more handles shall be placed on the longest sides, so located that the maximum weight supported by a handle shall be fifty pounds.

L = greatest length in inches
W = width in inches
d = depth in inches

c. If two handles are on one side, the distance between the handles shall be as great as possible. When handles are located on opposite sides of the transit case, the location of the pivots for the handles shall be on an imaginary line from 1/2 inch to 1 inch above the center of gravity of the transit case.

3.3.13.4 Cylindrical Type II cases.- In general, one handle shall be provided and shall be located on the longitudinal axis at approximately the point of balance of the equipment and case with handle grip parallel to the longitudinal axis. On cylindrical Type II cases of extreme dimensions, the number and location of handles shall be determined by the procuring activity.

3.3.14 Gasket application details.- The gasket shall be placed on the cover or body of the transit case in a retaining enclosure which shall protect the gasket against shearing thrusts. The gasket shall be securely bonded in place and shall have a minimum of joints. The gasket shall not be assembled with butt joints.

3.3.15 Spare parts transit cases.- In addition to meeting all of the requirements specified herein transit cases for spare parts shall also conform to the following:

a. The partitions of the transit case shall be so designed to accept the spare parts within a minimum of wasted space.

b. The compartments within the transit case shall be marked to clearly identify the parts to be contained therein.

c. Transit cases shall be designed to provide easy access to the spare parts.

d. The transit case shall be designed so it will not be necessary to unstack them for easy access to the parts when the transit cases are stacked.

3.3.16 Combination transit cases.- In addition to the requirements specified herein transit cases to be used as combination transit cases (see 6.1) shall be so designed to enable operation of the contained equipment inside the transit case (or outside of the transit case).

3.4 Finish and color.- Unless otherwise specified, finishes shall be in accordance with MIL-F-14072. The color of type I surfaces (as defined in MIL-F-14072) shall be color X34087 in accordance with FED-STD-595.

4. QUALITY ASSURANCE PROVISIONS

4.1 Responsibility for inspection.- Unless otherwise specified in the contract or purchase order, the supplier is responsible for the performance of all inspection requirements as specified herein. Except as otherwise specified in the contract or order, the supplier may use his own or any other facilities suitable for the performance of the inspection requirements specified herein, unless disapproved by the Government. The Government reserves the right to perform any of the inspections set forth in the specification where such inspections are deemed necessary to assure supplies and services conform to prescribed requirements. (See 6.2.d).

4.2 Classification of tests.- The inspection and testing of the transit cases shall be classified as follows:

- a. Preproduction tests(See 4.4)
- b. Acceptance tests(See 4.5)

4.3 Test conditions.- Unless otherwise specified, all tests required by this specification shall be made at prevailing ambient temperature and humidity conditions.

4.4 Preproduction testing

4.4.1 Preproduction test samples.- The preproduction test samples shall consist of models representative of the production equipment. The samples shall be identified with the manufacturer's part number and such other information as required by the procuring activity. (See 6.2.e)

4.4.2 Preproduction test reports.- When the contractor conducts the preproduction tests, he shall, after completion of the tests, prepare a preproduction test report when required by the contract according to the MIL-STD-831, and furnish three complete copies of the report to the procuring activity. (See 6.2.f)

4.4.3 Preproduction tests.- The preproduction tests shall consist of all tests described under 4.6 "Test methods". Tests shall be made in the order outlined herein.

4.5 Acceptance tests.- Transit cases shall be subjected to acceptance tests. The acceptance tests shall consist of the following tests as described under 4.6 "Test methods" of this specification.

4.5.1 Sampling tests

4.5.1.1 Lot.- For purposes of acceptance test sampling a lot shall consist of all transit cases submitted for acceptance at one time.

4.5.1.2 Sampling.- Sampling for acceptance testing shall be conducted in accordance with MIL-STD-105, inspection level II. The acceptable quality level (AQL) for major defects shall be 1.0 and the AQL for minor defects shall be 4.0.

4.5.1.3 Classification of defects.- Inspection and testing of the transit cases shall be conducted as follows:

<u>Category</u>	<u>Defect</u>
a. Critical	None defined
b. Major	
(1) 101	Fit of equipment in shock mountings
(2) 102	Dimensional correctness
(3) 103	Compression catch ease of operation and positiveness of action
(4) 104	Seating, number of joints and protection of gasket
(5) 105	Failure to pass air relief valve test
c. Minor	
(1) 201	Finish; for burrs, sharp edges, et cetera
(2) 202	Nameplate
(3) 203	Handle operation, size and location
(4) 204	Handle clearance

- | | | |
|-----|-----|--|
| (5) | 205 | Permanence of installation of shock proofing material and mounts |
| (6) | 206 | Defective hardware |
| (7) | 207 | Completeness |
| (8) | 208 | General over-all visual inspection. |

4.6 Test methods

4.6.1 Mechanical inspection tests.- The transit cases shall be given a thorough mechanical and visual inspection and test to determine that the quality of all materials and workmanship is in compliance with the requirements of this specification and the following:

- a. Fit of equipment in shock mountings
- b. Finishes (see 3.8)
- c. Nameplates, identification markings and labels
- d. Correctness of dimensional data
- e. Handle operation, size, and location
- f. Handle clearance
- g. Compression catch ease of operation and positiveness of action
- h. Seating; number of joints, and protection of gasket
- i. Permanence of installation of shockproofing material and mounts
- j. Defective hardware
- k. Completeness
- l. Welded joints (MIL-STD-454 Req 13 & 24)
- m. Check of mounting means (MIL-STD-454 Req 9)
- n. Check of lubrication and rust prevention
- o. Check of safety features (MIL-STD-454 Req 1)
- p. General over-all visual inspection

4.6.2 Mechanical tests.- The transit case shall be subjected to the following mechanical tests:

4.6.2.1 Air relief valve test.- Transit cases equipped with air relief valves shall be tested to insure that the valves function in the proper manner when exposed to pressure differentials.

4.6.2.2 Static load test.- The transit case shall be given a concentrated load test as follows:

a. Rectangular transit cases - A loading platform as shown in Figure 1 shall be placed on the center of the transit case side. Sand shall be poured and spread level in the loading platform. The sand and the loading platform shall weigh 100 pounds. The load shall be applied for three hours. The maximum allowable deflection shall be 1/4 inch. The load shall then be removed and the allowable permanent deformation shall not exceed 1/8 inch. This test shall be performed on all six sides.

b. Cylindrical Type I cases - The Type I case shall be placed in a compression machine, so that the moving platform will make line contact with center of the elements of the cylinder. The minimum line contact shall be four inches, and the maximum line contact shall be 12 inches. The loading platform shall move at a rate of 12 inches per minute. A load of 100 pounds shall be applied for three hours. A maximum deflection of 1/4 inch is allowable. The load shall then be released, and a maximum permanent deformation of 1/8 inch is allowable. There shall be no splitting of seams or cracking of welds as a result of this test.

4.6.2.3 Impact test.- The transit case shall be given an impact test as follows:

a. Rectangular Type I case - A tube 8-1/2 feet long, inside diameter of 1-9/16 plus or minus 1/32 inch, shall be used as a guide for the impact missile. An impact missile as shown in Figure 2 shall be used. The center of all six sides of the case shall be marked. The tube shall be placed in a perpendicular direction on the center of side of the transit case. The missile shall be inserted in the tube up to the gage mark, and released. This test shall be performed on all six sides of the case, a total of six impact blows. The maximum allowable permanent deformation shall be 3/8 inch. There shall be no puncture, fracture, or splitting of the side or corners of the transit case.

b. Cylindrical Type II case - The impact test for cylindrical transit cases shall be identical to the test performed in 4.6.4.a, except for the location of impact points, and total blows. The center of the top, bottom, and a spot on the center of an element of the cylinder shall be marked. The test shall then be performed as described in 4.6.2.3.a. A total of three blows shall be performed. There shall be no puncture, fracture, or splitting of the Type II case. The maximum allowable permanent deformation shall be 3/8 inch.

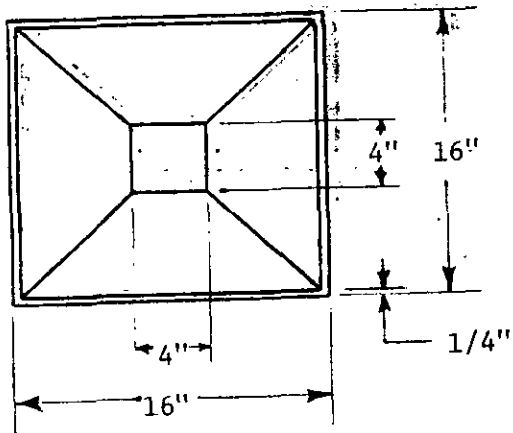

LOADING PLATFORM IS A HOLLOW
FRUSTRUM OF A PYRAMID CLOSED
AT SMALL BASE, FORMED BY WELDING

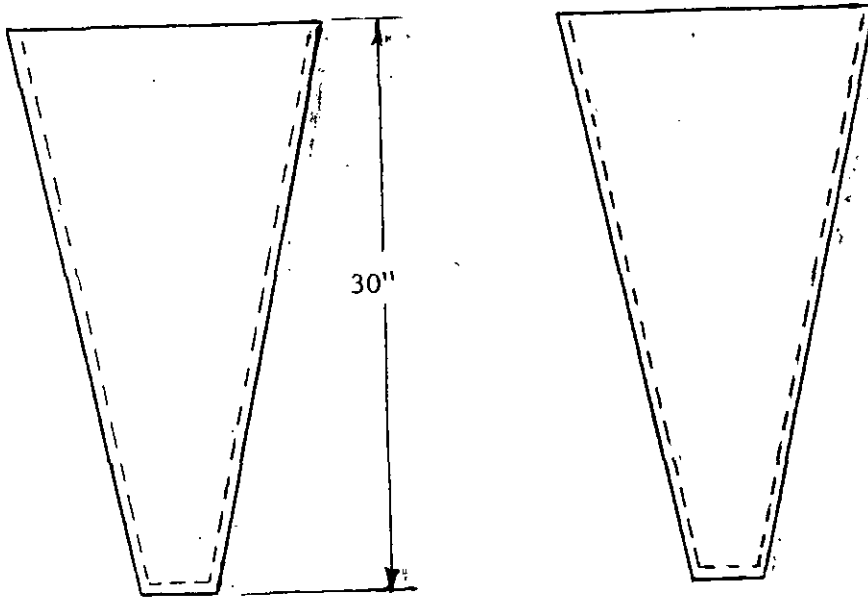

LOADING PLATFORM

FIGURE 1

MAT. ANY METAL.
MIN. THICKNESS 1/4"

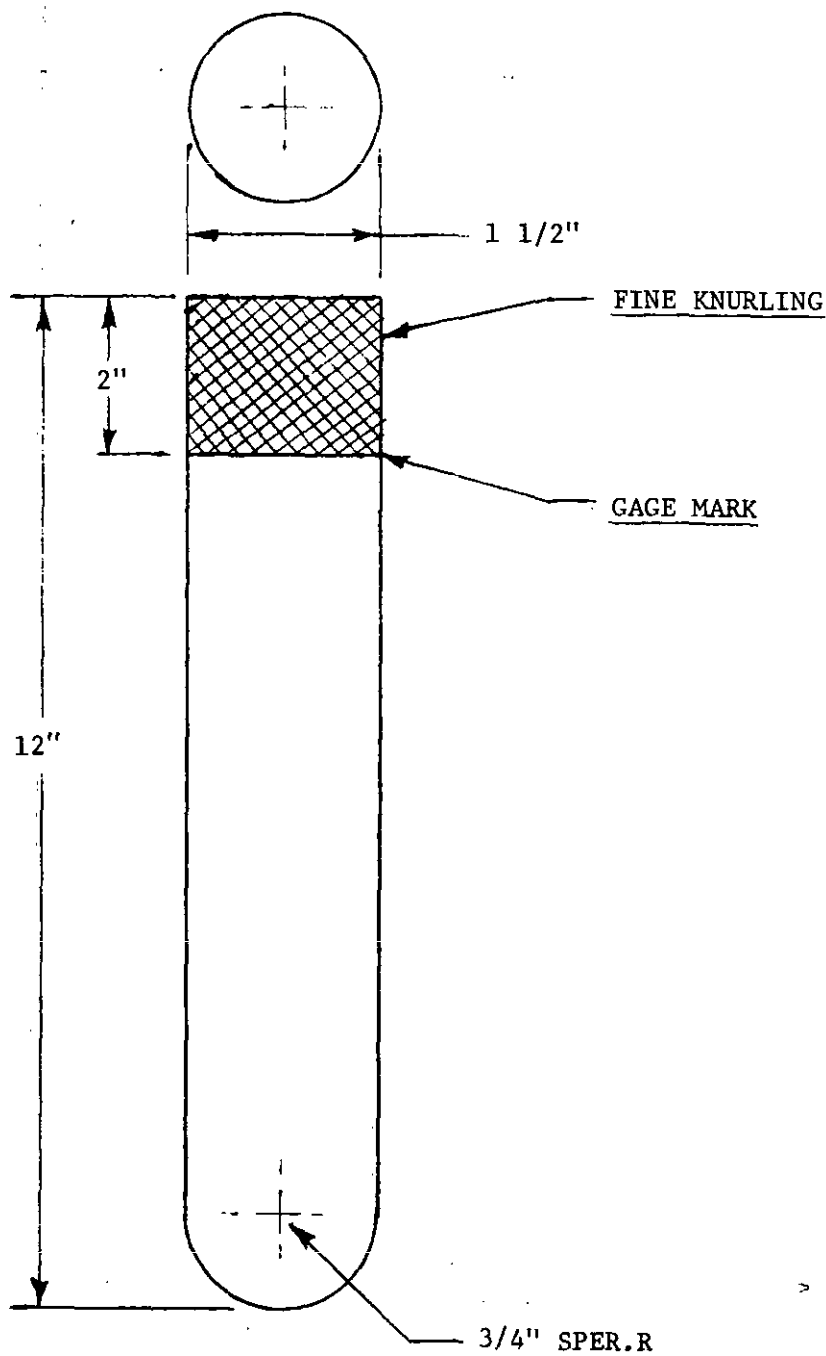

MISSILE

MAT. STEEL

FIGURE 2

4.6.2.4 Bounce test.- The bounce test shall be conducted on a package testing machine which has a capacity of 1000 pounds and a table measuring 5 feet by 5 feet, LAB Corporation Type 1000E, or equal. The transit case with a dummy load equivalent to the weight of the housed equipment shall be placed, unpackaged, on the floor of the package testing machine. The machine shall be set to run at 285 revolutions per minute (RPM), both synchronous and nonsynchronous drive. The rectangular transit case shall be subjected to the bounce test for a duration of 3 hours: 15 minutes on each face for a total of 1-1/2 hours with synchronous drive and 1-1/2 hours with nonsynchronous drive. Cylindrical Type II cases shall be placed on the tester so that the cylindrical surface is against the floor, and the tester run at synchronous drive for 1-1/2 hours and nonsynchronous drive for 1-1/2 hours. Upon completion of test there shall be no evidence of damage to the case such as openings along any joints, loosening of partitions, splitting of corners or opening catches.

4.6.2.5 Handle pull test (rectangular and cylindrical transit cases).- The transit case shall be subjected to the following handle pull test. The transit case shall be loaded with a dummy load equivalent to the weight of the housed equipment. A rope, 1 inch minimum diameter and 10 feet long, shall be securely fastened from the handle to an overhead. The rope shall be taut as a result of supporting the transit case at least 12 inches away from the floor level. The case shall then be raised so that the bottommost part of the transit case shall be 4 feet from the floor. The transit case shall then be released. There shall be no evidence of separation of handle, splitting or cracking of metal in the transit case. A maximum deformation of 1/4 inch out of true shall be allowable for the handles. The test shall be performed on the handles of each side and shall cause no malfunctioning of the handles. (NOTE: If there are N handles on a side, then N parallel ropes shall be used in the above test, and the height of drop in feet shall be computed with the following formula: $H = 3/N$, where H = height in feet, N = number of ropes.)

4.6.2.6 Drop test

a. Rectangular Type I case - A dummy of the size, weight and shape of the equipment shall be placed in the transit case and the cover shall be locked in place. The transit case shall then be dropped 14 times from a height as designated in Table II on a concrete surface of a minimum thickness of 2 inches. One drop shall be made on each of the eight corners and on each of the six faces of the Type I case. There shall be no evidence of damage to the case such as openings along any joints, loosening of partitions, splitting or cracking of case material. Any partial or total opening of catches shall be a cause for the rejection of the case.

TABLE II

<u>Weight of Case and Equipment in Pounds</u>	<u>Height of Drop in Feet</u>
Up through 90	4
90 through 120	3
120 through 180	2
180 and above	1

b. Cylindrical Type II case - A dummy of the size, weight and shape of the equipment shall be placed in the Type II case and the cover shall be locked in place. The Type II case shall be dropped 4 times on the top, 4 times on the bottom, and 4 times on the cylindrical surface, a total of 12 times, from a height of 4 feet on a concrete surface. The concrete shall have a minimum thickness of 2 inches. There shall be no evidence of damage to the transit case such as opening along any joint, loosening of partitions, splitting or cracking of case material. Any partial or total opening of any catch shall be a cause for rejection of the Type II case.

4.6.3 Environmental test.- The transit case shall be subjected to the following environmental conditions:

4.6.3.1 Humidity test (rectangular and cylindrical transit cases).- Before conducting this test, the cover shall be locked, then unlocked by its catches at least 10 times. The cover shall then be securely locked in place. The case shall then be placed in a humidity chamber and subjected to the humidity test per Method 507, Procedure I of MIL-STD-810. There shall be no warpage or evidence of corrosion at the completion of this test.

4.6.3.2 Salt spray test (rectangular and cylindrical transit cases).- Selected hardware items and completed transit cases in the quantity as may be required by the procuring activity shall be subjected to the salt spray test specified in Method 509 of MIL-STD-810. The items tested shall show no failure detrimental to the function for which they were intended.

4.6.3.3 Submersion test (rectangular and cylindrical transit cases).- The Class 1 case, when placed in any possible position and with no portion of it less than 3 feet below the water surface, shall show no evidence of water penetration after being submerged in tap water for a period of 4 hours. The temperature of the water shall be the same as the ambient temperature.

4.6.3.4 Splash test.- The Class 2 transit case shall be subjected to this test. The transit case shall be placed in the bottom of the tank as shown in Figure 3. The transit case shall be closed with all catches locked in place. The nozzle shall be kept at a perpendicular distance of 24 inches from the center of the nearest side of the transit case. The water shall be turned on, and shall have a minimum pressure of 35 pounds per square inch at the nozzle. The temperature of the water shall not exceed the ambient temperature. Figure 4 shows the suggested design of the nozzle. The water flow shall last for a period of 2 hours, and the test shall be performed on all six sides for a total time duration of 12 hours. At the completion of final run the transit case shall be withdrawn from the tank, wiped dry, and examined internally. There shall be no evidence of moisture within the transit case.

5. PREPARATION FOR DELIVERY

5.1 Packaging and packing.- The packaging and packing requirements of the case shall be specified by the procuring activity.

5.2 Marking.- Interior and exterior marking shall be in accordance with MIL-STD-129.

6. NOTES

6.1 Intended use.- The transit cases covered by this specification are intended for housing and transporting ground electronic, communication, and navigation equipment. Combination cases are intended for housing and transporting this equipment, in addition these cases also permit the equipment to be operated inside (or outside) the case. The spare parts cases are intended for transporting and housing spare parts for the equipment.

6.2 Ordering data.- Procurement documents should specify the following:

- a. Title, number, and date of this specification
- b. Kind of case, its type, and class
- c. Condition under which design approval will be granted.

(See 3.3.1)

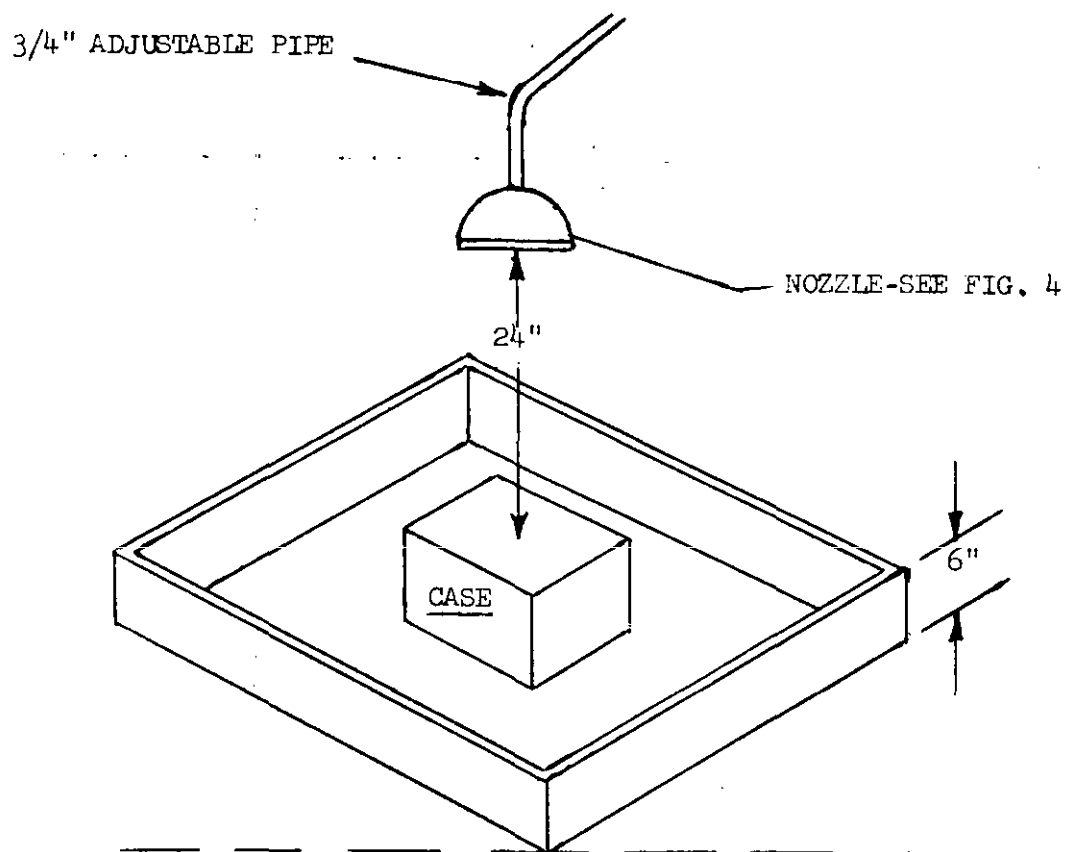

TANK SHOULD BE LARGE ENOUGH TO HOLD CASE WITH A
MINIMUM CLEARANCE OF 2" ON EACH SIDE

FIGURE 3

SMALL RING HOLES-60° APART
OTHER 2 RINGS-30° APART

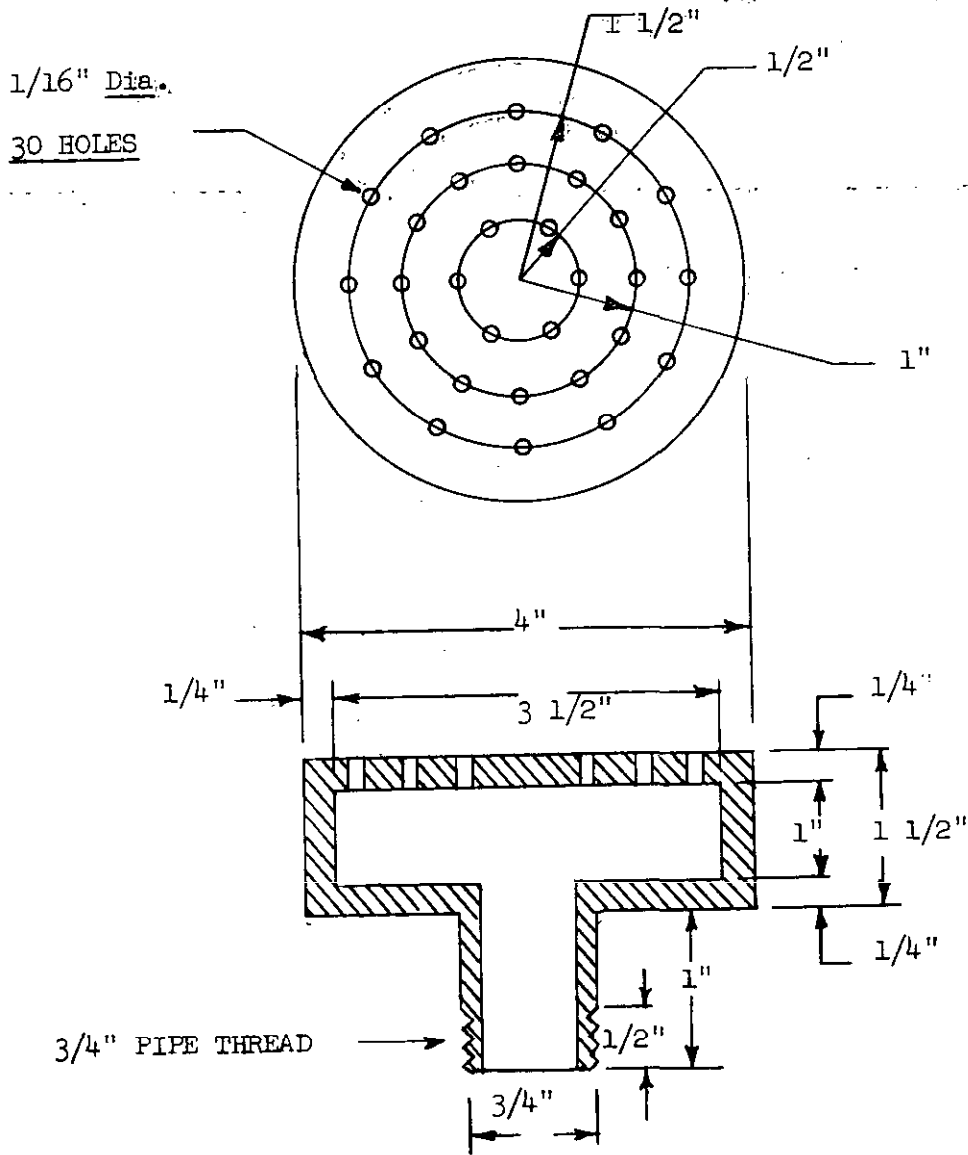

NOZZLE CONSTRUCTION

FIGURE 4

d. Whether the testing will be conducted by the procuring activity or by the contractor. (See 4.1)

e. Quantity of preproduction samples to be tested. (See 4.4.1)

f. Whether a preproduction test report will be submitted by the contractor and when this will be accomplished. (See 4.4.2)

g. Applicable levels of preservation, packaging and packing required. (See 5.1)

6.3 Definitions

6.3.1 Submersible case.- A submersible case is a case capable of meeting all test requirements specified in section 4. (NOTE: The terms "submersible case, submersion-proof case, watertight case, and waterproof case" are considered synonymous for the purposes of this specification.)

6.3.2 Splashproof case.- A splashproof case is a case capable of meeting all test requirements specified in section 4, except the submersion test. (NOTE: The terms "splashproof case, moistureproof case, spray-tight case, and dripproof case" are considered synonymous for the purposes of this specification.)

★ U.S. GOVERNMENT PRINTING OFFICE: 1981-703-023/4750

Custodian
Air Force - 17

Preparing activity
Air Force - 17

SPECIFICATION ANALYSIS SHEET

Form Approved
Budget Bureau No. 22-R255

INSTRUCTIONS: This sheet is to be filled out by personnel, either Government or contractor, involved in the use of the specification in procurement of products for ultimate use by the Department of Defense. This sheet is provided for obtaining information on the use of this specification which will insure that suitable products can be procured with a minimum amount of delay and at the least cost. Comments and the return of this form will be appreciated. Fold on lines on reverse side, staple in corner, and send to preparing activity. Comments and suggestions submitted on this form do not constitute or imply authorization to waive any portion of the referenced document(s) or serve to amend contractual requirements.

SPECIFICATION

ORGANIZATION

RAIC (EMIDS)

CITY AND STATE

CONTRACT NUMBER

Griffiss AFB New York

MATERIAL PROCURED UNDER A

DIRECT GOVERNMENT CONTRACT

SUBCONTRACT

1. HAS ANY PART OF THE SPECIFICATION CREATED PROBLEMS OR REQUIRED INTERPRETATION IN PROCUREMENT USE?

A. GIVE PARAGRAPH NUMBER AND WORDING.

B. RECOMMENDATIONS FOR CORRECTING THE DEFICIENCIES

2. COMMENTS ON ANY SPECIFICATION REQUIREMENT CONSIDERED TOO RIGID

3. IS THE SPECIFICATION RESTRICTIVE?

YES NO (If "yes", in what way?)

4. REMARKS (Attach any pertinent data which may be of use in improving this specification. If there are additional papers, attach to form and place both in an envelope addressed to preparing activity)

SUBMITTED BY (Printed or typed name and activity - Optional)

DATE

DD FORM 1426
1 JAN 66

REPLACES EDITION OF 1 OCT 64 WHICH MAY BE USED.